

II. The Major Arcana (Presented In Hebrew Alphabetical Order)

1. The Sun (☉). The first letter of the Hebrew alphabet is **Aleph** (Greek Alpha A, α) and shows a bull's head. Aleph means bull, although it is often glossed as "ox". An ox is a castrated bull. The proper meaning of the letter is the creative life force of the bull, not the docility of the castrated ox. The primary icon of this Trump is a large sun high in the sky. The illustration of the Sun Trump traditionally has the features of a human face. This suggests a connection with the brain. The sun is the source of all life on our planet and controls its growth and prosperity. In the body the brain carries out a corresponding function as an organ. The sunburst has bright rays extending from it in all directions. This represents the power of the sun to transmit energy. This energy is electromagnetic and is the same energy that the brain sends to all parts of the body via the nervous system. The letter ALePh represents unity (1), the starting point of life and the Creative Source. It also represents 1000, the plenitude of life. The ancients associated cattle with the sun and considered them holy. They often ritually sacrificed bulls in order to attract wealth. Cattle represented the largest single asset that a nomad might possess and thus naturally symbolized wealth. The yellow color of cattle matched the color of sunlight and the color of gold, a metal valued for its brilliant solar sheen. The sun's rays were bull's horns. The halo nimbus around the head of a saint represents the electromagnetic aura of a highly energized brain, rays of light emerging from the head. (See for example Michelangelo's horned statue of Moses.) This symbolism also integrated higher intelligence with the horned beasts that roamed the planet. Later Christian artists relegated horns to devils and demons. All parts of cattle could be utilized, and so in ancient cultures a golden cow or bull came to represent the life-bestowing power of the sun. In Egypt the love-goddess Hathor (Heth-Hor, "House of Horus") came to represent the space of the sky in which the midday sun (Horus) resides. The Egyptians often drew her icon with a cow's head and horns. Apis was an Egyptian bull deity. In Hebrew he is ABYR, the Almighty Hero who 'flies' (ABR). [ABR as a noun means wing, and by extension, the penis.] Eber (OBR) was the namesake patriarch of the Hebrews. A-PR is the A-bull. Additional impetus to the cult of cattle was given by the emergence of the alphabet during the Taurian (Bull) age. This made it especially appropriate to begin the alphabet with the letter A, the sign of the bull. Thus there is a special connection between the Sun and the Sign of Taurus. The latter is associated with the High Priest (Pope or Hierophant) because the ancient chief priest sacrificed bulls to the sun god and thereby served as an intermediary between man and god. There is also a connection to the Judgment Trump (letter R), the first zodiac sign where the Sun begins its journey, and because AR is 'light' and RA is both 'to see' and the Egyptian Sun god's name. The Egyptian source for the Sun Trump is Amen-Ra, the Hidden Sun or transcendental creative intelligence, the Source of all life. In the Odyssey Homer tells of a herd of sacred cattle on the Island of the Sun. The English capital letter A still retains the pictograph of the bull's head with its horns. The bull's ears have been clipped off, and the head is turned upside down, but you can still recognize the image. Although the sunburst is the primary icon on the first Trump, we also often find a portrayal of Adam and Eve as children in the Garden of Eden. The name Eden (OD-N) refers to a small place that holds Eternity (OD). The pair are often shown holding hands within a circle that represents the eternal cosmos.

2. The World (𐌌, 𐌔). The second letter is **Beth** (Greek Beta B, β) and is a pictogram of a house, a mansion, a palace, or a temple. The primary icon of this Trump Card is the figure of Gaia, the Goddess of Earth. She is often naked (sometimes with a scarf fluttering about her) and usually holds two wands. The wands connect her to the Magician, and her dancing pose connects her to the Hanged Man. This pose also matches the dance of Shiva. Gaia dances within a green wreath that represents the plant life that abounds on our planet's surface when it flourishes in good health. It is also a laurel wreath, sign of victory and success and sacred to Apollo, God of the Sun's Creative Energy, prophecy, music, medicine, and poetry. Zoomorphic angels anchor the corners of the card. These are the four H*aioth, the Living Beings that guard or anchor the Heavenly Emerald Throne (the Heart Chakra). (See Ezekiel 1:10 and Revelations 4:7, 7:1) These four angels represent Taurus (the spinal cord -- High Priest), Leo (the corona radiata and sensory/motor nerves -- Strength), Scorpio (the third ventricle and pineal with its ray of intuition -- Death's scythe), and Aquarius (the cerebro-spinal fluid -- the Soma alchemy of Temperance). The eagle is the airborne version of the scorpion and represents the eagle-shaped third ventricle in the midbrain with the pineal gland (scorpion's tail, the Angel of Death's scythe) poised in its center. These four Zodiacal Archangels anchor the four seasons and the four directions. Later a general convention developed to place angels at the corners of maps, a vestige of the H*aioth Archangels. The Living Beings also represent the four key aspects of alchemy -- sulphur, mercury, water, and gold. The wreath of the Earth is round, but the four H*aioth anchor the corners of the picture into a square or rectangle. The letter Beth represents a house. Its original Egyptian pictograph is simply a square or rectangular enclosure (𐌌, 𐌔). Later forms became more elaborate, or simplified into a cursive form (𐌔). The World Trump stands for the skin, the organ by means of which we touch our World. Thus it is important that Gaia be naked. The skin forms the tent that a person lives in and carries wherever he 'camps'. The skin protects internal organs from the environment and regulates body temperature. Thus the first two Trump cards present the God of Transcendental Heaven and the Goddess of Earth, the Master computer of the creative Mind and the physical interface for touching and feeling our World. In ancient Egypt Earth or World was the male deity Seb. He was also called Geb, another name for the goose that was his totem. Seb often is shown sprawled on the ground to represent gravity and earth. One leg is extended, but the other knee is cocked and the foot is pulled in close to the knee. If you turn the picture on its side you will find that he is in almost the same posture as Gaia. Try it yourself, and you will find it a very relaxing posture for reclining. You can rest one hand on the cocked knee and prop your head with the other, or you can extend that arm and rest your head on the upper arm. This ancient Egyptian representation of the Earth God explains the curious pose that Gaia traditionally has in the World Trump cards.

3. The Chariot (♈). The Chariot facilitates rapid motion. This icon represents the Will. Physiologically the Will is centered in the breast. A mother nurtures her child at her breast. The Will nurtures the development of Life. The Will has unlimited power to take you wherever you want to go. It both nurtures and protects. Thus it corresponds to Cancer, the crab -- armored on the outside, but soft inside. The icon of this Trump usually shows an armored warrior mounted on a chariot drawn by two steeds. One traditional version shows the two steeds as bare-breasted female sphinxes. This emphasizes the connection with the breast. The Hebrew letter **Gimel** (Greek gamma Γ, γ) actually means a camel. The ancient nomadic Hebrews wandering in the desert did not have war chariots. A chariot is not much use for travelling on desert sand. The nomad's vehicle of choice was the camel. The camel is strong enough to carry riders or heavy burdens and can survive during long treks across the arid desert by storing water in its hump(s). The letter Gimel is simply a pictogram of the camel's hump, leaving out the other details. The camel's hump is also an excellent symbol for the woman's breast, the primary vehicle that nourishes the child during his first years. Women usually cover their breasts with protective garments. This protection is shown in the chest armor worn by the warrior.

The warrior wears a coronet with stars and has over his head a canopy with stars on it. The chariot often has the Egyptian Aten winged solar disc displayed on its front. The Hebrew word for the Chariot is Merkabah. This is the type of chariot used by God and the angels according to the Qabbalists. It can take you anywhere you want to go instantly (or within whatever time frame you believe is appropriate.) The Merkabah has no speed limits. Its Egyptian name MER-KA-BA means "Love, Orgasm, Breath". Love is the ultimate vehicle to get you wherever you want to go. The Ka and the Ba are two of the eight "souls" that each person possesses. The two steeds that pull the chariot of love represent these two souls and their polar aspects. The Ka is the electromagnetic current in the nervous system. The Ka's most extreme experience is the Orgasm felt at the Creation of Life and the Creation of Death. The Ba is the breath that provides gas exchange for the body. The mind's thoughts ride on the vehicle of the breath. Control of the breath allows one to control the mind. Thought and Breath are the two poles of the Ba. Orgasm and death agony are the two poles of the Ka. The winged disc is the standard insignia of qualified air force and commercial pilots throughout the world and represents their freedom to fly where they will. Pilots generally wear this insignia on the chest, usually over the heart. The breast is a universal symbol of the nurturing quality of love. The ancient Egyptian (as well as the Mesopotamian, Hindu, Tibetan, the Chinese, and probably also the Mayan) cultures all shared at some level of purity a cultural secret regarding the tantric technology for enhancing the Will's power by manipulation of electromagnetic Life Energy and the Breath.

Horus the Warrior is the Egyptian god for the Chariot. He has a hawk's head and wears the crowns of upper and lower Egypt. He holds the ankh of Life in one hand and his other hand grasps the "tail" of his throne. He wears scale armor over his chest and a golden pectoral. His chariot in the background sits ready to go. His glyph says "Horus, the Great Neter". In the background we see the Aten flying disc.

4. Priestess (∇). The fourth letter of the Hebrew alphabet is called **Daleth** (Greek Delta Δ, δ), which means "door". But the pictograph chosen for this letter does not resemble the doors that we are familiar with. Recall that the Hebrews were often nomadic and lived in tents. The door to a tent is a flap of cloth that folds back and has the delta shape of a tent. The Trump card of the Priestess shows her sitting in the doorway to a temple. The doorway is flanked on either side by a pillar. As with the pair of sphinxes pulling the Chariot, one pillar is usually white, and the other one is black. This suggests Manichaean duality. However, there is a special secret meaning to the appearance of a pair of columns or towers on a Trump Card. The esoteric suggestion here is that they represent the legs and hence an aspect of the lower portion of the body. To get a deeper appreciation of the iconography of a Trump Card with pillars or towers, you must turn it upside down.

The priestess herself forms the delta shape of the doorway. The delta-shaped female *mons veneris* heralds the doorway of the vagina, that special entrance into the secret and sacred temple of the human body where life magically shapes a new body. The priestess sometimes wears a veil, and the doorway behind her is covered with a hanging arras that often has emblems from the Temple of Solomon embroidered on it. The figures on the curtain depicted in several versions of this Trump show pomegranates arranged in the form of a Tree of Life and interspersed with palm trees. The pomegranate is a symbol of fecundity. Women demurely cover the entrance to their Temple of Life, and the Islamic tradition of veiling women is an extension of the tradition of keeping this place secret and forbidden to all except the especially invited initiate. Muslims take the imagery literally and cover the faces of their women. This is a misinterpretation of a convention that only holds for the High Priestess. Nature even provides a virgin with the hymen, a thin membrane 'veil' of skin that partially drapes across the entrance to the vagina. When a woman allows a man entrance to her Temple for the first time, he must pierce through this thin veil. The description of the Temple of Solomon in the Bible explicitly mentions the use of the palm tree and the pomegranate as decorative designs. These are symbols of male and female sexual fecundity.

The dark pillar on the left side of the picture has the letter B inscribed on it, and the light pillar on the right has an I inscribed on it. These letters represent the Hebrew names of the pillars as given in the Bible (Kings I, 7:21). The B stands for B-OZ ("In the power"), and the I stands for IaH-KeN ("God is confirmed"). Frank Baum's story **The Wizard of Oz** is actually a Qabbalistic tale about unfolding the Power (OZ) of Life in oneself. Applying the Qabbalistic principle of Notariqon to the letters on the pillars we discover that B is the first letter of the first word of the Torah (B-ReShIT), and I is the first letter of the last word of the Torah (ISRAeL). The Priestess sits between the pillars holding in her hand a copy of the Torah. The Torah is in the Temple -- or at least it is in the Doorway to the Temple. Using this powerful shorthand principle of Notariqon we also find that we can translate **B-I** by itself to mean "In Me." Thus all the secrets of Life are in the Self, in God, in the Torah, in the Temple, and inside the vagina of the Virgin Priestess. Incidentally, a reversed reading of the letters I-B gives us the Egyptian word for the Heart, informing us that we should open the Heart first before we open the door to the Secret Temple. Sex without Love is not the way to go. Some decks show a

crescent moon at the feet of the Priestess. When we invert the card the crescent is also properly inverted and depicts the pubic bone, below which the pubis appears. The watery flowing of the lower garments about the crescent suggests the presence of the bladder behind the pubic bone. Prominently displayed in the center of her crown we find a large clitoral bulb marking the doorway to the Temple of Mysteries. It also forms the top of her crown, suggesting the connection to the Crown Chakra. The columns also have a very phallic look about them.

The Priestess represents the power of hidden assets. She wields great seductive power, but does not need to do very much since she controls the access to a space that contains something of great value. Mathematically this efficiency takes the form of a triangle in two dimensions, and a tetrahedron in three dimensions. The pyramids of ancient Egypt are icons of Isis, the Priestess. Inside the pyramid the mummified body of a pharaoh becomes Osiris, husband of Isis. The mummy becomes a giant phallus that rests forever inside of the Temple of Isis enjoying the eternal bliss of Union. Isis often wears her glyph, the throne, like a crown. In our Egyptian card she holds the ankh in her left hand to symbolize immortal Life. Over her right arm she holds draped a leopard skin. This recalls her firstborn son, Babai, master of the phallus. As a great tantric yogi he showed Osiris the technology that transmutes orgasm and death into immortal bliss. The leopard skin also represents the arras veil and the book that the Priestess holds. The ancient Egyptians introduced hieroglyphic writing. Most anciently this was done on animal skins. Later Thoth revealed the technology of manufacturing paper from papyrus. The orderly rows of spots on the leopard skin resemble the rows of hieroglyphs written on papyrus. The Book of the Dead with the recipe for immortality was often placed in pyramid tombs. The text could be inscribed on the stone walls and sarcophagus, painted on the coffin, or written on papyrus scrolls placed in or near the coffin.

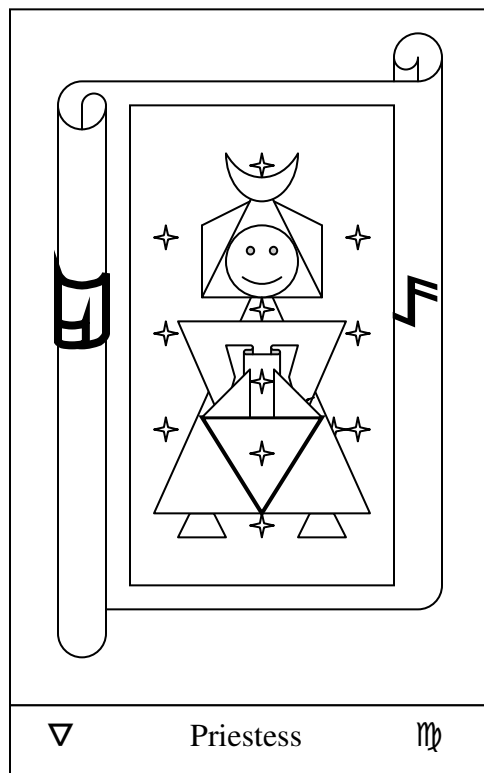
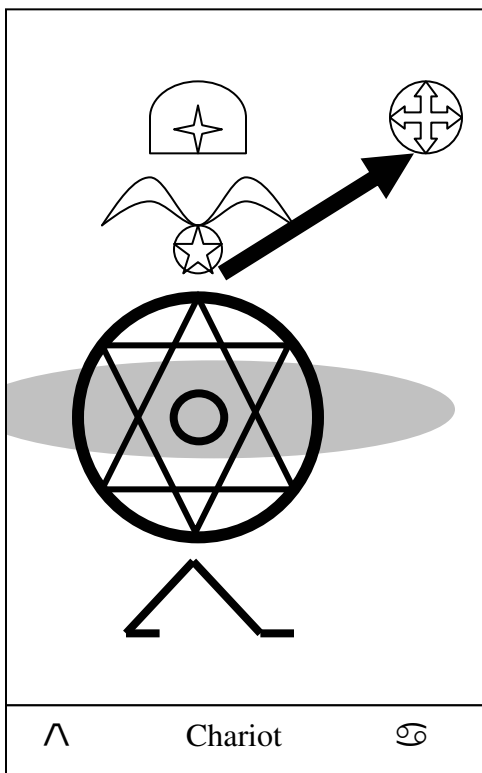
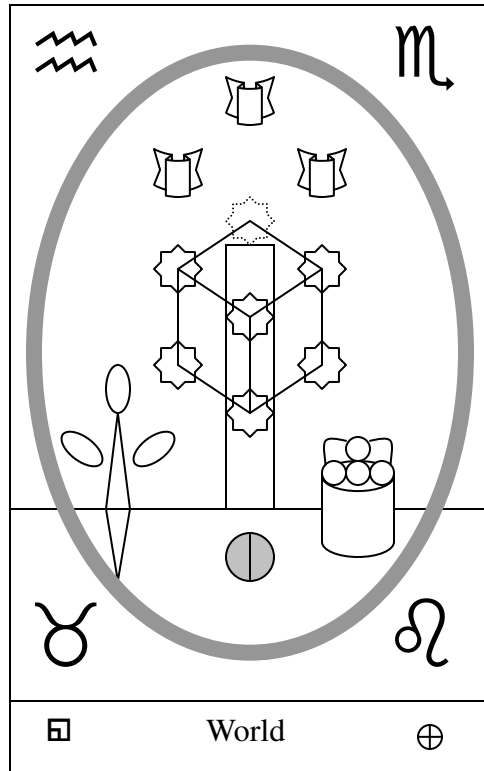
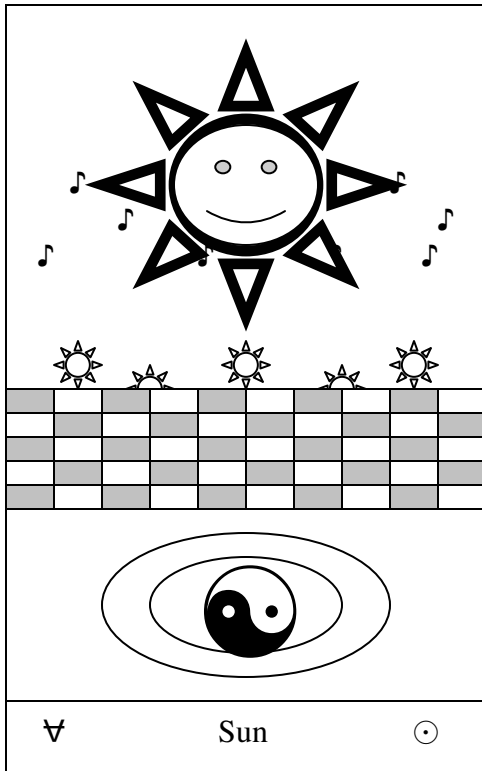

5. The Emperor (𐌺). The fifth Hebrew letter is **Hey** (Greek Epsilon E, ε) and forms a pictogram of a farmer's flail. In the Greek form of the letter the handle of the flail was left off. In ancient Egypt the flail became a symbol of the Pharaoh's responsibility as the head of state to oversee successful pursuit of agriculture in order to guarantee the feeding of the population. Farmers used the flail to beat the harvested grain and thereby separate the kernels from the chaff. The lighter chaff would blow away in the breeze, while the grain would settle into the winnow. Hey is the letter of the breath because the flail swings about in the air and releases the chaff into the air. The organ of breathing is the respiratory system (lungs and bronchial tubes). We can go without food or water for a while, but we usually die within minutes if we stop breathing. The Emperor holds the power of Life and Death over his populace. This Trump usually shows an Emperor, wearing a crown or helmet and armor, seated on a cubic throne (symbol of the World) and holding a scepter of power and an orb of power. Scepter and Orb are both ankhs, the Egyptian symbol of Life. The ancient pharaohs sometimes held ankhs (a simplified Tree of Life), and sometimes held the flail (symbol of the lungs) and also the crook (symbol of the nerve links) and sometimes also the tsham or uas power scepter (symbol of the spine and its connection to the brain). The long-handled ankh has a male energy, and the fat orb-shaped ankh has a female energy. In the Middle Ages the orb with the cross on top was taken to mean Christ's dominion over the World. The Emperor, with the blessing of the Pope, became His "representative". This was all political adaptation of the original symbols to fit the Roman Catholic Imperial agenda. The ram's head icon that often appears on the Emperor's throne or armor is a connection to Aries. The Emperor is, of course, the first and highest citizen in the land. But he really relates to Zeus/Jupiter, the Imperial Lord of the Gods. The Aryan Ram actually can be the challenger to the Emperor's throne. He represents courage, fortitude, and perseverance, all qualities important for an Emperor, but absolutely critical for a challenger.

The Emperor often sits in the open in a mountainous terrain. Such places usually have very good quality air and are excellent for the practice of intense pranayam breathing disciplines. The Emperor exercises his Will to manage his Mind via breath control. Of course, it works the other way too. You can use a mental technique to modify the breath or other parts of the physiology. Air holds the earth like the Emperor holds the orb.

The first pharaoh of Egypt's First Dynasty was Men. This name is the same as Amen or Min, the Hidden One, the original creator god of the Egyptians. Min is an agricultural fertility god, and he characteristically holds a flail in the air and wears an ostrich plume headdress, signifying the breath, air, and his spiritual nature. He is also ithyphallic, signifying his generative power as a nature deity and a secret tradition of spiritual practice that involves the combining of sexual energy with secret breathing techniques. The Emperor of Atmosphere is the ancient Egyptian deity, Shu, who often holds 2 ankhs.

Some versions of the Emperor Trump show a heraldic eagle. The eagle is an imperial symbol. It represents authority and high vision. The bird is a symbol of the spirit and of the element of air. Both of these are the proper characteristics of the Emperor. Zeus had a pet eagle, and Shu wears an eagle feather like an Indian brave. This goes back to the Vedic idea of the third ventricle in the brain. The eagle flies high in the mountains.

6. The Pope, High Priest, or Hierophant (Υ). The sixth letter is **Vau** (Greek Digamma F) and means a nail or hook. Actually it is the shepherd's crook. A poor shepherd just used a forked stick -- hence the Hebrew letter's shape. The Greek name Digamma means two gammas. This letter evolved into the Roman F and the English "double-u" (W), but the Greeks dropped it, preferring to create the letter phi (Φ, φ) for their harder "f" sound. They then created another letter called Omega or "Big O" (Ω, ω) for W and put it at the end of their alphabet. The omega had the basic sound of Vau as it is often used in Hebrew -- a "w" sound. You can see that the Greek little omega (what a contradiction!) actually looks like an English "w". It also sounded similar. The Greek phi looks like an O with a slash drawn through it. Perhaps that meant that you made an O (or digamma W) sound and then made it unvoiced, resulting in the "f" sound.

The Greek-speaking early Christians (and many Christians today) like to refer to God as "Alpha and Omega", the Beginning and the End of the alphabet, and therefore of all creation. I suspect that the Big Omega (now we have become redundant!) was the sign for Taurus, the Bull ♂, inverted. If this is true, it means the Greek alphabet begins with a bull's head A, and ends with a bull's head ♂ inverted into Ω. This is a bit amusing, since the Greek A already was the Hebrew א inverted. The alphabet comes from the Taurian period and the ancients of that period worshipped the bull as a symbol of the Sun's creative energy. In spite of Moses smashing the golden calf as idolatry, the bull remained the image of God and the symbol of material wealth to many ancient people. You sacrificed a bull to God, and He gave you wealth in return. You were already pretty wealthy if you could sacrifice a bull. So for many Greeks God literally was Alpha and Omega. Now you know why that phrase still comes up in Christian liturgy.

The crook was another symbol of power held by the Pharaoh in ancient Egypt. Even today the Pope in Rome carries such a crook as his staff of authority. Both the Egyptian crook and the Pope's crook resemble a hook. This may be the origin of the ironic expression "by hook or by crook" that means we will get something one way or another, even by some sneaky means. In modern parlance a crook is a thief. Originally the Pharaoh's crook represented his responsibility as the head of state for overseeing animal husbandry and all its products and benefits. In his role as the "shepherd-in-chief", Pharaoh managed the people as his flock. He was the Head Priest, or Pope, the highest spiritual medium in the Empire. As such he mediated between the Great Sun God and his constituents. The Sun is the Source of Life. It communicates by its radiation with all life forms. The pharaoh Akhenaten believed so much in the Sun as the Source of Life that, in his role as spiritual guide of Egypt, he even tried to have the Sun God supplant all other Egyptian deities.

The brain communicates with the various organs of the body by means of the nervous system. This is a network that links all components of the system together. In a society priests, mediators, and other specialists in spiritual matters and communication play the role of the nervous system. Oddly, all the pictures we have of Akhenaten show him as well as his wife Nefertiti and their children with abnormally large brains.

In the background of the High Priest Trump illustration we see two pillars. They remind us that the lower part of the nervous system is very important and that we must invert the card to discover some details. The Pope carries a staff that represents the spine. At the top of the staff are some cross bars that form a delta shape. This delta is the sacrum (holy bone), several vertebrae that are fused together. From holes in this bone sprout the main nerves connected to the lower part of the body. Where they branch out of the sacrum is called the "horse's tail" or cauda equina. Behind this area is the seat of the Kundalini Life Energy. Proper stimulation of the pressure points at these holes helps enliven the Kundalini energy.



Another notable part of the Pope's equipage is his high tiara decked with a network of floral ornaments. This represents the male's frenulum and the female's clitoris. These two formations contain some of the densest clusters of sensory nerves in the whole body, aside from the retina of the eye and the pads of the finger tips (both of which are also referenced in this Trump. Stimulation of nerves in the frenulum and clitoris generate intense sexual arousal. These nerves communicate directly with the kundalini (prostate and G-spot) and the midbrain to generate the ecstatically pleasurable sensations of orgasm. It is ironic that Popes throughout the ages have tried to deny such feelings, implying that indulgence in them is "bad" and that people should practice celibacy except for the procreation of children. The Tarot definitely has a sense of humor when it symbolizes sexual arousal with the tiara worn by a supposedly celibate priest. The ancient Pharaohs had no such sexual inhibitions and were definitely not celibate. Akhenaten also would cover his head with an extra high tiara. Then he and his beautiful wife Nefertiti used to walk around naked. He was an interesting High Priest.



The BOTA pope also has a crescent moon decoration on his collar that, as usual, stands for the pubic bone and further confirms our interpretation of the papal tiara. The Pope holds two fingers erect symbolizing the importance of erection and pointing specifically at his tiara). He is not blessing his acolytes, he is reminding them of something important. The BOTA card shows several X-marked points on the papal throne and dais, as well as the hands and feet of the pope. Most obvious are the crossed keys. These "Keys to the Vatican" mark the point at the base of the skull where the two trunk lines of the spinal cord cross over to reach opposite hemispheres of the brain. One of the acolytes is actually touching the keys so we do not miss the importance of this crossover point. The other acolyte presses his palms together to show the coherence between the two sides of the system. The handles of the keys form important marma points for the Mouth of God at the rear of the skull. These points help activate the Medulla Oblongata, the primal brain stem. The medulla is the home of primal instincts that the aspirant brings into conscious communion for the purpose of purification and management. The two acolytes wear robes decorated with white lilies (pure love) and red roses (the flower of the Tree of Life and the Rosy Cross). The lily is shaped like the Star of David ($\nabla\Upsilon\Delta$). David means "beloved". The petals of the rose stand for the 22 letters of the Hebrew alphabet: the 3 Mothers, 7 Planets, and 12 Zodiac Signs. We can view the tonsured heads of the acolytes as the highly sensitive testicles or perhaps as eyeballs. The surplises of the acolytes display the branching Y-shaped glyph of the ancient Hebrew character Vau quite clearly. The nervous system has a characteristic

structure of branching from the brain to all the various organs of perception and action. It is a communication network.

The Papal Trump corresponds to the House of Taurus ♉, the return of the Sun, the ox's spring plowing and the bull mating with his cows. The nervous system connects directly to the brain. The brain is the Sun and the nerves are the Sun's rays of light. The horns on the bull are also the Sun's rays. Have you ever wondered why it is that when the Pope speaks officially he issues a written communication called a Bull? The Latin term Bulla refers to the large round seal that is placed on the document making it official. This is usually translated as a bubble, knob, or amulet. It is all of these, and it goes back to ancient Egypt. Whenever the Egyptians wrote the name of a pharaoh, they put a bubble around it. Nowadays we call that a cartouche. The first Egyptian words that were deciphered were names such as Cleopatra that appeared in the cartouches. A cartouche bubble carved in stone represented the royal seal. In China even today all official documents for everyone in the country have to be sealed with a cartouche in red ink. The person's name is carved in reverse on stone or ivory or wood with a bubble frame around it. The bubble stands for the brain. The brain holds the identity of the person. It is like a picture of that person. Comic strip characters speak their minds with speech bubbles, and think their thoughts with thought bubbles. The artist writes the words within a cartouche placed over the person's head. The ancient Egyptians believed that a person's name was one of his eight souls. They called it a ren. When someone calls out your name, something in you recognizes that this means you. That is your ren-soul. Call someone by their name and watch them respond. You can see their soul by how they respond. The Pope's hands are upraised in the sign of the Ka, Even today the Pope and priests in general still make this Ka gesture when they say Mass.

Among the Egyptian gods, Tehuti (Thoth) is the High Priest. Traditionally he officiates over the most important ceremony of ancient Egyptian religion – the weighing of the heart. He records the results with his staff of authority -- a writing brush -- on a strip of papyrus. Thoth has the head of an ibis. In Egyptian it is called tekhi, a pun for the heart-shaped weight used to adjust the accuracy of the scale. Our word “technology” comes from this. Thoth is the lord of writing – the key to the evolution of tradition, science, technology, education, and medicine. He often wears a triple branched tiara with horns of Khnemu, a pair of uraei, and symbolic acupoints on it.

NAME   **REN (mouth) + (sound of speech)**  **Ka**

Y **Q L Å W P A T* R A T** 

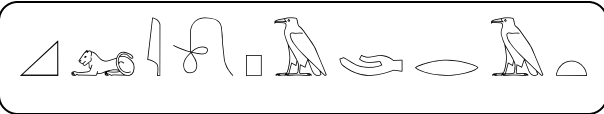

7. Death (Z). The seventh letter is Zain (Greek Zeta Z, ζ). The name of the letter in Hebrew means a weapon, and the shape of the letter nicely matches the large scythe that the Grim Reaper carries. The main icon of this Trump is a standing skeleton with a grinning skull -- the Angel of Death. This Trump Card depicts the bone structure that supports all the organs in their respective positions while the body engages in activity. Without the framework of bone structure we would have a difficult time moving about on land. The bones represent a solid framework, the outline of the body.

When we die, most of the body rots away quickly, but the bones remain much longer. When we complete a project, the various details involved in its execution fall away, but the essential frame of the plan remains, especially the goal, or harvest that we reap from its execution. The Reaper uses the scythe for harvesting the final fruits of Life. This card is about completion, letting go, and moving on. Scattered about on the ground are hands, feet, and heads from dismembered people. When a project is finished, we do not need hands and feet to run around and do things, nor do we need a head to think about the plan. We let go of all that and enjoy the harvest of our efforts. The Living Dead do nothing and enjoy everything. Perhaps this is the secret of the rock band, Grateful Dead.

On the Death Card there usually is a head with a crown among the body parts on the ground. Death shows no respect for the high born. At the horizon a new day dawns. The rising sun represents a new birth of Life. The Waite version shows the sun rising exactly between two towers. This clearly signifies rebirth. The sun could be setting, but sunset implies sunrise and makes more sense as a contrast to the theme of Death. We invert the card and discover that the dawning sun is a new baby's head emerging from the mother's womb. The tower specifically recalls Magdalene, the beloved follower of Jesus, and the traditional Grail vessel. The placing of the sun between two towers is also a sign of archeo-astronomy, the sacred science of the ancient megalithic cultures. These cultures understood the cycles of nature that constantly self-renew. This is the gateway to immortality, and Death is the herald to this major portal. The pair of tower-legs also spell BaBa in Egyptian, reminding us again of the Master of Immortality.

The river in the background represents the continuous flow of Life and the river Lethe. Sometimes a single rose reminds us that all possibilities of Life are always available, even in Death. Sometimes Death wears a dark cape and cowl, the dark abyss of the soul when we lose consciousness, and sometimes he rides on horseback as one of the four horsemen of the apocalypse (see Revelations). Europe in the Middle Ages went through the terrible scourge of the Black Death. This impressed in the minds of people the impermanence of Life in the Body, and established the figure of the Grim Reaper, or Memento Mori (Reminder of Death), as a universally recognized cultural icon.

In Egypt the Lord of Death was Anpu, the black dog. He received the corpse and oversaw the preparation of the mummy. He also adjusted the tekhi weight at the center of the Scale of Justice and read off the results so Tekhuti could record them in his report to Amen. At death we weigh our entire life in terms of its core value, the Heart.

8. Hanged Man (⚊). The eighth letter is **H*eYT** (Greek Eta H, η and the Hebrew number eight.). This letter is a pictogram of a cord or thread (⚊Y⊗) or a net (⚊PW). (⚊F⊗ is a tailor.) The name H*RM, is very important for the Tarot, since it is one of the names that Thoth, the author of the deck, goes by. In his famous text, the **Emerald Tablet**, Thoth refers to himself as ⚊PW XTX W⚊FYX (H*RM TLT MH*\$VT). This is usually translated as Hermes Trismegistus, or Thrice Great Hermes. The last name probably means "From Grace" (W ⚊F∇), or "Mage of The Secret" (W∧ F FY∇). Hiram appears in First Kings as the friend of Solomon who helps build the Great Temple in Jerusalem. His name in the Bible is written as ⚊FPW. Hiram came from Tyre (RP), the "Stone" city, an important Phoenician port in Lebanon north of Israel. According to the Bible Hiram's mother was Jewish (of the Naphtali tribe) and his father was Phoenician. Hiram made all the brass fittings as well as the brass pillars that adorned the Temple (See ∇, the High Priestess). Hermes Trismegistus was one of the founders of alchemy. Some people believe that Thoth/Hermes/Hiram/Hermes Trismegistus/Mercury are all the same person, an immortal who has been on earth since the time of Atlantis. Drunvalo Melchizedek believes that Thoth recently (around 1992) left the Earth plane and ascended to a higher realm to carry on his mission in a different manner.







The Hanged Man Trump Card shows a man hanging from a wooden frame by a rope tied to his ankle. The rope is the key icon for this Trump, and the Hanged Man's strongly emphasized legs are the parts of the body that are most important for this card. The Hanged Man's heel keeps the rope from slipping off. Although he hangs in this awkward inverted position, he appears quite relaxed. He folds his hands behind his back and crosses one leg behind the tied leg at the knee. His hair hangs down and his head on some cards glows with a nimbus. Perhaps he is enlightened. He generally wears long stocking pants that accentuate his muscular legs, and he wears a tunic that has buttons down the front and crescent moons below the waist. The moons stand for the kidneys, and the buttons represent the chakras. Two large tree trunks usually support the top beam from which he is suspended. The branches of the trees have been removed, leaving six knots or limb-stumps on each trunk -- a total of twelve -- one for each sign of the zodiac, or one for each son of Jacob, the Heel.

Some occultists identify the Hanged Man with Christ, but Christ was not crucified upside down. The organ of the body intended by the Hanged Man is the muscular system, including the tendons that extend from them -- especially the Achilles' tendon. The body's largest muscles are in the legs. The iconography of the card draws special attention to the Hanged Man's legs. The two tree trunks also suggest legs and remind us to invert the card and consider the man's lower body. When we invert this card, a funny thing happens: the Hanged Man floats in the air upright, tethered to the beam as if he were a helium balloon. This odd image suggests the test of the heart in the ancient Egyptian Hall of Judgment. The heart should be lighter than Maat's feather of Truth. In this case the Hanged Man's entire body is so light that it seems to float in the air. The light around his head adds to the effect. Thoth/Hermes demonstrates the art of floating.

Our muscles help us to overcome gravity. They only work by contracting. This means that we must have pairs of opposing muscles that cooperate in order to move. Standing

requires both pairs of leg muscles to pull in opposite directions, creating tensegrity, or integrated tension. The Hanged Man is in what seems to be a stressful situation. Yet he is relaxed. This is a key principle.

The habit of the muscles to contract when they do work tends to lead to a buildup of tension and stress in the body. It even looks opposed to our goal. To stretch out our arm we must contract a muscle. That's an inverted way of doing something. To shoot an arrow at a target we pull the arrow on the bow in a direction directly away from the target. The whole thing looks backward to someone ignorant of the principle that tension on the bow generates potential energy available to move the arrow in the direction we desire. An athlete knows that he moves faster and more efficiently if he can relax all his muscles before he starts moving. Otherwise he must either struggle against himself or waste time relaxing and then tensing on the fly. The striated muscle fibers resemble the braiding of ropes and threads. The rope in the Trump Card is a particularly notable feature and represents the pictogram of the letter. The muscles enable all the organs to move about and achieve their goals in the field of dynamic action. Thus I place the Hanged Man, as the archetype of Mankind, at the head of the "cosmic" list of the Trumps. Without muscles we can live, but we can not move about and accomplish physical goals with our bodies.

The Egyptian letter pronounced H*:  (A Braided Rope.) This rope can also represent a net, a bed or hammock, a [rope] ladder, or a staircase. In Egyptian the staircase was pronounced Khet (with a velar fricative similar to H*). It was written as  (with the phonetics  and sometimes with an additional radical ) and was the tool given by Ra to Horus so he could help Osiris up to the firmament lens or membrane (diaphragm) that separates earth and heaven. Sometimes it was called "aqt er pet" the staircase to heaven. As a ladder it is sometimes pronounced Maqt, written like the old Hebrew letter , and called the ladder of Set. The ladder connects between lower and upper chakras. The Pope (High Priest) makes a mudra pointing upward with index and middle fingers. Thoth as High Priest mediates for Ra and teaches this secret mudra to Horus so he can help raise Osiris up the ladder. See also Budge's discussion of these symbols as ancient Egyptian amulets (See **Egyptian Magic**, (NY: Wings Books, 1991), pp. 51-55, 62.) The Egyptian firmament is the same as the one described in the opening passage of Genesis. The  symbol (also pronounced khet) is a tree branch. It can represent a tree, a branch, wood, a pole, plank, board, or a tablet. Khet en Ankh is the "staff of life" and refers to food derived from plants. With the knife radical khet means to cut, engrave, or inscribe hieroglyphs and reliefs on a wall. The Egyptian word khet appears on the Tarot card as the tree-frame from which the hanged man hangs. (Also H*ad is a fishing net in Egyptian. H*et is a word for the heart, and H*edi is a name for the flying solar disc. H*esa is a rope or string.) The muscles and ligaments of the body connect to the skeletal frame and enable us to climb the ladder of life. The upside down posture of Hanged Man is Horus, as Hero in the Womb for nine months. The rope is his umbilical cord. He sits on (dangles from) a lotus placenta. He communicates with his mother by moving his leg muscles. He sucks his thumb, indicating dependence, but wears the crowns and holds the staffs of his future authority.

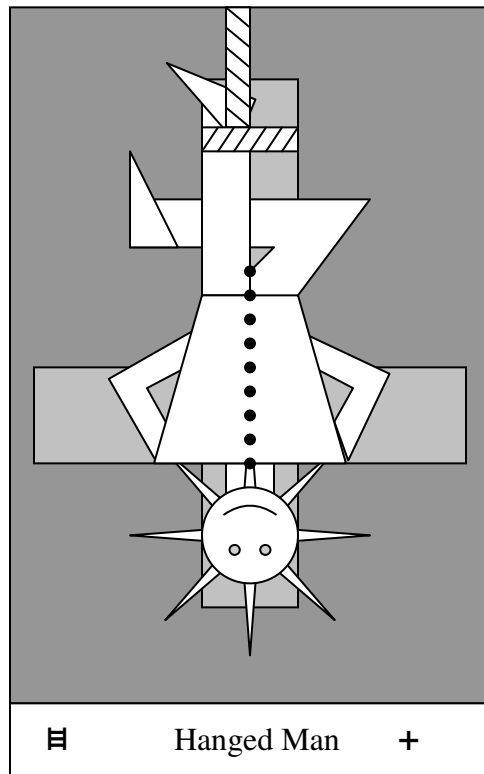
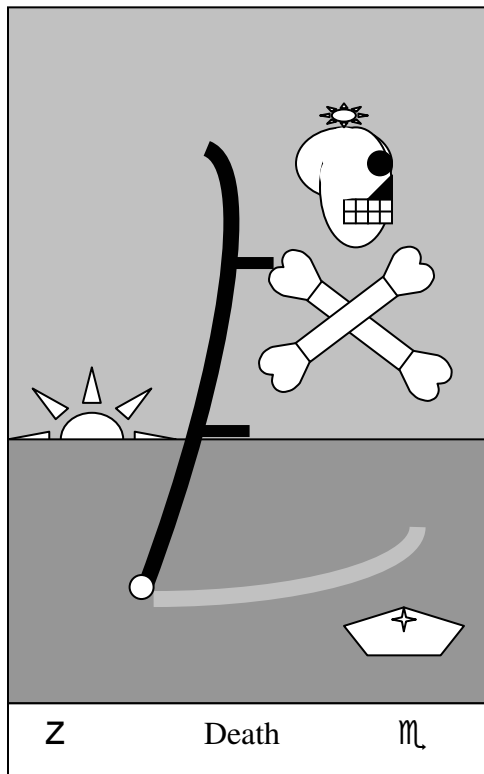
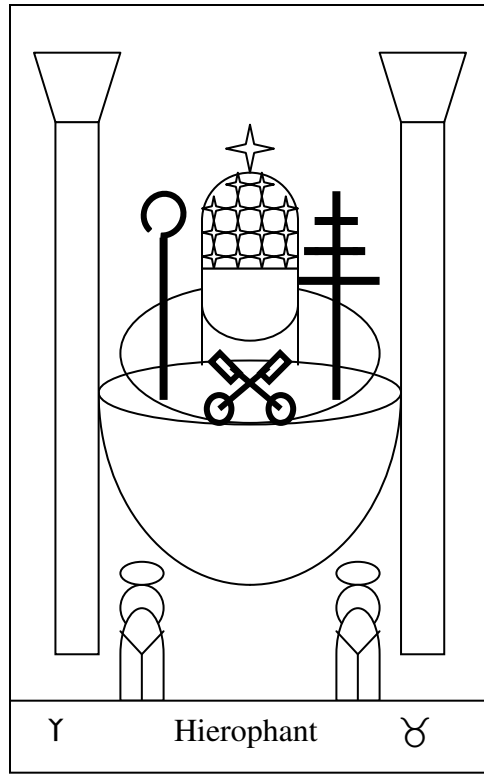
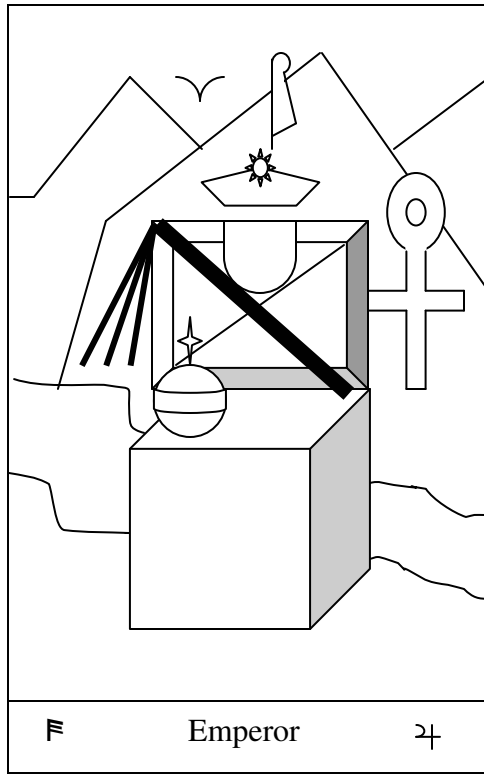

9. The Wheel of Fortune (⊗). The ninth letter is **T*eIT** (Greek Theta Θ, θ and Hebrew number nine), and has the meaning of a wheel. **T*aBUR** is the umbilicus. This is the proper name for the letter. **T*AT*** is "to sweep" and probably refers to the circular sweep of a rotating bar or beam. **T*IT*** is clay. If we substitute the similar sounding T for T*, then we get **ThaTh** ('under'), a name for Thoth in Hebrew. The Trump card depicts a Wheel poised in space or mounted on a frame. The Wheel is an icon for the pictogram of the letter and the navel of the human body. The Wheel has eight spokes. Each cardinal direction in the central region has an alchemical symbol labeling it. We find the 3 Mothers (Sulfur, Mercury, and Salt) together with Water (the sign for Aquarius). Salt has the symbol Theta, which is the Greek form of the Hebrew letter **T*et***. I suspect that Salt and Water (or Sulfur and Mercury) should change places so as to let the Wheel's alchemical sequence match the zodiac symbols at the corners of the card: Lion, Eagle Water Bearer, and Bull.

On the outer rim of the Wheel we find distributed at the cardinal directions the letters T, A, R, and O. Completing the circle forms the French spelling **TAROT**. But the letters can be read in many ways: **TORA** (suggesting the Torah), **ROTA** (Latin for "Wheel"), **ORAT** (Latin for "It speaks"), **ATOR** (for Hathor), and so on. There are altogether 24 permutations of these four letters. This tells us for one thing that the Wheel of Fortune works according to the statistical laws of Chance. All possibilities exist and the Wheel systematically explores them all. In the semi-quadrants we find the Hebrew letters for the Tetra-grammaton, **YHUH**, or **YaHVeH**, or **YeHoVaH**. These letters also can permute, but do not produce as many possibilities because the letter H occurs twice in the set. The name Yahweh derives from the root **HVH**, to be. But it also means lust, mischief, destruction, or calamity. Thus all creations in the universe partake of the nature of God: They come into existence, screw around for awhile, and then self-destruct. In our discussion of the Temperance Trump we will go deeper into the meaning of the Tetragrammaton (four-letter name of God).

Notice that the name "Tet" occurs in Tetra-grammaton, so there is an important connection between the number four and a Wheel or cycle. Any cycle divides nicely into four major phases that correspond to the four cardinal directions. The Greek word four happens to contain the names **Thoth-Ra**. The sun (Ra) wheels about in the sky above and the wheel of fortune rolls about down below (Thoth) in the physical world. Four in Egypt stands for the physical world. The four Living Beings in the corners of the card are Archangels. These are the same four Living Beings that we find in the corners of the World Trump. Various editions of the card show different creatures climbing up or down on the Wheel. The **BOTA** version has the serpent Apep sliding down the left side and Set flying up the right side, bearing the Wheel on his back. On the top of the Wheel is a Sphinx holding a sword. The sword represents the ability to decide, and the Sphinx represents the Higher Self's ability to make decisions through Intuitive Wisdom so that actions are aligned with Source and reflect the Will of the Higher Self for the greatest good of all. The Wheel turns on and on, repeating its pattern of behavior over and over in endless cycles. These cycles may not go anywhere at all, or can take you wherever you want to go. The Sphinx has the ability to drive the Wheel in the same way that she can pull the Chariot. The navel is a vestigial mark on the body.

It marks the center of mass from which the body grew as a clump of cells. It is the nave of the Wheel of a person's life. It holds the past connection to the Mother for life support during the sojourn in the womb. It also rests between the second chakra emotional energies that attach to past experiences and the third chakra mental identity Ego that builds a future. The Ego gains power through the illusion of "rightness". Nobody wants to be wrong. So the Ego resists being wrong and asserts a Self Identity as the chosen path in Life that a person takes. This determines his Fortune -- his future development. However, Life is an integrated wholeness, so the Wheel always turns to let the Ego experience the other side, the mirror flip of its chosen identity -- the part that it resists and claims is "not I." The Wheel of Fortune recapitulates as every chakra and every acupoint (marma point). The Sanskrit chakra, means Wheel and refers to any energy center in the body that contains nerve ganglia. Major chakras also have glands associated with them. The Wheel also has a particular function in the organ of hearing. The ear is a special navel center. Through the exploration of subtle hearing one may return to Source and awaken the Sphinx of the Higher Self. The key to the icon is the silent nave or hub of the Wheel and the transcendental Sphinx who can control the Wheel.

Oswald Wirth drew a wooden frame holding his Wheel of Fortune suspended in the air so that it looks quite mechanical. But the whole frame appears to be floating over some kind of liquid. This, of course, represents the bladder. At the base of the frame is a crescent moon with its corners turned down. This we recognize as the pubic bone. The board that forms the body of the frame is the spine with its central shushumna channel. Coiling up from the base are two serpents that represent the ida and pingala channels. Thus the Wheel schematically suggests the whole chakra system and the Kundalini energy that can rise up to clear the chakras. The Sphinx has its wings outspread suggesting an awakening. The lion body is a solar image. So this reminds us that raising of the Kundalini energy can awaken the Intuition and its connection with the Higher Self. Then the Wheel of Fortune may even fly wherever it will, just like the winged disc on the Merkaba Chariot.

In Egypt Fortune is the god of success and abundance, Shai. He appears next to the Heart under the frame of the Scales of Judgment. To find out the great secret of the Egyptian Wheel of Fortune, read about Khnemu on pages 248-256.

Here is a Latin Wheel of Fortune formula. It is a perfect palindrome, and reads horizontally or vertically, up to down, down to up, right to left, and left to right.

SATOR	The Creator
AREPO	is slow moving.
TENET	He holds
OPERA	his creations
ROTAS	in vortices.

You will find hidden in this curious anagram the names of many important Egyptian deities written in Latin spellings: ASAR (Osiris), ATOR (Hathor), SAT (Isis), SET, ERO (Horus), TET (Thoth), NET (Nut or Neith), RA, ATEN. Also you find the name of the Book of the Dead: PERT EN ERA.

10. Strength (♁). The tenth letter is called **Yod** (Greek Iota I, ι). The name of the pictograph chosen for this letter means the "hand", and this tells us the body part associated with this letter and Trump. The real strength of the hand comes not from its muscular power, but from the sense of touch in the fingers and the ability to perform fine manipulations. The hand is our biological component that specializes in making the transition from idea to physical form. When we make or do something with our hands, we translate subtle mental thoughts into electrical impulses that activate the hands to move about in extremely complex ways to modify our environment. The letter ♁ (Y, I, or J) is the pictogram of a hand with the arm bent upward as if in the process of reaching for something. It can also be a wing extending. The Trump card's icon shows a calm matronly woman dressed in a long gown and wearing flowers in her hair. She reaches down with her bare hands and gently tames a wild lion. The lion appears to be roaring (or possibly yawning), but it is not resisting her touch. A wreath of roses entwines around his golden mane. Over the woman's head floats a nimbus in the shape of a "lazy-8" infinity sign. On some cards the lady wears a large, floppy hat suggesting the nimbus. The Zodiac sign for this Trump is Leo. Right next to Leo in the zodiac is Virgo. The Trump shows how the subtle charm of Virgo can overcome the wild power of Leo. The subtle heart is stronger than the raw physical forces of nature.

These two signs are neighbors in the zodiac, and the outer planets (Mars, Jupiter, and Saturn) follow them in our list. The three forces of these planets -- self-cultivation, breath control, and karmic fortune -- can strongly influence the application of Strength. The Empress (Venus) has a special relation with the Emperor (Jupiter). So we find that Virgo's Strength comes from purity of Heart (Mars), the power of all-embracing Love (Emperor/Empress), and the Rhythmic Cycle of Nature (Saturn).

Virgo (I) and Leo (Not I) achieve unlimited Strength by fusing into a single being, the Sphinx, or Higher Self. The Sphinx has ultimate power over the course of events, because its Will (see Chariot) expresses a broad and patient plan that benefits all. The "I" and "Not I" function as a complete wholeness. Some believe that the Great Sphinx in Egypt dates back to the time just at the junction of the Ages of Virgo and Leo during the precession of the equinoxes. We can look at the precession cycle relative to the center of the Milky Way galaxy. The apogee point (when the North Pole of Earth's axis tilts closest to Galactic Center) is the Age of Satya Yuga. According to some beliefs that is the era of greatest wakefulness and coherence on the planet, whereas the perigee point (farthest from Galactic Center) is the Age of Kali Yuga, a time when awareness falls into sleepy confusion.

Whether there is any relation between the precession cycles and the average level of planetary awareness may depend largely on viewpoint. There might be some climatic cycles, since the precession influences the Earth's tilt with regard to the Sun. At any rate nature seems to operate in cyclical patterns over time, so history evolves in a spiral motion as the axis wobbles around in a cycle like the hour hand on a giant clock. We are now in transition from the Era of Pisces to the Age of Aquarius. Each zodiac age lasts slightly over 2000 years, the whole precession taking nearly 26,000 years. That is what we see when we look from Earth up into the sky -- the dawning Age of Aquarius.

Therefore the Virgo-to-Leo transition occurred almost 13,000 years ago. The Virgo-Leo juncture is exactly 180 degrees out of phase with our current position. It occurs exactly at the opposite side of the precession. In other words, the Earth is NOW at the position in the cycle that lies right between Virgo and Leo -- passing through Virgo's third eye -- while its axis leans pointing toward the Pisces-Aquarius junction. In any case the infinity nimbus over Virgo's head reminds us to open our third eye up to the Higher Self, and through it to wake up to the unbounded Strength of Pure Awareness. No power, however strong, can overcome Source Awareness.

The ancients believed that the greatest pace of noticeable change in society occurs just shortly after the apogee and perigee points in the precession cycle. The extreme points of the cycle are the Aries-Pisces transition and the Libra-Virgo transition. The most recent such extreme point was 2000 years ago at the transition from the Roman Republic into the Roman Empire. The offset junctions when rapid change and trend reversal occurs are at the Virgo-Leo transition and the Pisces-Aquarius transition. To understand this principle, think of the temperature lag between the shortest day of the year at Winter Solstice and when the coldest part of winter arrives about a month later. After the coldest point the weather gradually will start to warm up again. Well, here we are now at the Pisces-Aquarius junction. So fasten your seat belts (or maybe you should unfasten them)! Powerful changes are taking place on Planet Earth right now. This is an ideal time to slip into enlightenment.

There is an esoteric interpretation of this card. Virgo discovers her latent Life Energy through pleasuring herself with her hand. Although the lion on the Trump is usually drawn as a male, the woman's inner wildness probably harkens back to the Egyptian cosmic lion goddess Tefnut, who becomes the earthy lioness, Sekhmet and her tamer incarnation, the cat goddess, Bast. In the traditional Egyptian company of gods Tefnut is the sister and consort of Shu.

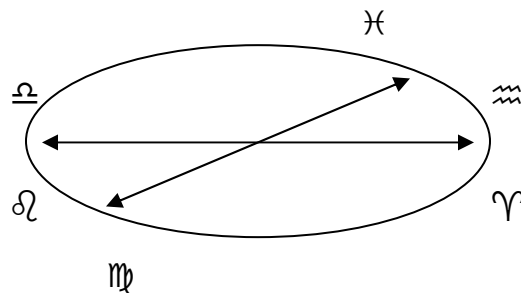

11. The Hermit (Y). The eleventh letter is **Kaph** (the Hebrew number 20 and the Greek letter Kappa K, κ). The letter is a pictogram of an upraised hand showing the palm with the fingers spread and indicates the palm of the hand or a cave. The icon of the Trump usually shows a bearded man in a cape and hood, grasping a walking stick in one hand and a lantern in his other hand. He holds the lantern aloft, grasping it from above by a handle on its top. When the hand grasps, it encloses something within the palm. The cave is the enclosure that forms the Hermit's abode and place of spiritual practice. The lantern functions as a cage holding light inside. Some of the light shines out from between the bars of the cage only if the shutters on the cage are open. The light carried by the Hermit has the shape of a six-pointed star, the Star of David. This star is the Qabbalistic sign of love. The conjunction of two triangles spells in Hebrew the word Love or Beloved. In India the six-pointed star is the traditional sign for the Heart Chakra. The organ that we associate with the Hermit is therefore the Heart -- the pump that circulates blood throughout the body. The heart sending out blood is like a lamp sending out light. The cage of the heart-lantern is the rib cage. The desires of the Heart grasp at things. The hands just express this mental grasping as a physical act. Once it has grasped something, the heart then closes up like the palm closed to form a fist. The closed heart hides its light like a lamp hidden in a cave. But the Hermit can release his Heart from grasping and allow its innate light to shine forth.

The Hermit Trump emphasizes the value of taking time to meditate, contemplate, work out issues and come to a space of integrity and honesty -- to open up the Heart Chakra. One character identified with the Hermit is Diogenes the Cynic. The ancient Greek school of Cynics believed that the two most important qualities in a man were courage (self-control) and honesty (virtue). There is a story that Diogenes used to wander about carrying a lantern even in daylight. He would walk up to people and shine the lantern in their faces. When they asked what he was doing, he replied that he was looking for an honest man. Nowadays a cynic is a person who is skeptical of ideals and believes all people are really just motivated by selfishness. So the challenge of Diogenes was to find someone able to transcend the limitations placed on the Heart by the selfish Ego.

Another character identified with the Hermit is Moses. As a young man he went off into the desert so he could listen to his Heart and find his True Mission. Later, as an old man he led the Israelites through the desert to the Promised Land. But he always remained somewhat aloof and separate from the people he led and died just before the end of the wilderness trek. Moses carried as his walking stick the staff of Hermes, a bronze staff with serpent coils on it. Other famous Hermits include Jesus, John the Baptist, and many of the early Christian saints. Anyone practicing self-cultivation to open the Heart and bring its light of Honesty to the world is a "Hermit".

In ancient Egypt the Heart was the key part of the soul weighed in the Balance of Justice. The Bennu, or Phoenix, was a symbol of the Immortal Purified Heart of Osiris. The goal of cultivation was to achieve the Phoenix-like heart of Osiris. The frame of the balance with its extended arm and pendant pan that contains the heart is the origin of the Hermit's upright pose with his staff and outstretched arm that grasps from above the lantern of the Heart.

12. Justice (♃). The twelfth letter is **Lamed**, the "Teaching" (Hebrew number 30 and Greek letter Lamda Λ, λ). The Hebrew letters generally are pictographs of objects from the daily life of the Hebrews, not abstract ideas. Of course we can think of Justice as a fine ideal, and certainly the many detailed laws laid down in the Torah suggest that the ancient Hebrews had a lot of ideas about "Justice". They also did a great job of pretending that "God" had laid these laws down for everyone to follow. There seems to be no question that the Tarot Trump of Justice is actually the Zodiacal House of Libra, since both emphasize the scales as a tool for achieving balance and fairness.

However, this simple explanation bothered me. With an odd abstract definition such as "The Teaching" I suspected the name for this letter represented a euphemism for something both important and taboo. Whereas it is true that scales would be used every day in the marketplace to weigh produce and other wares, I did not understand why the framer(s) of the Tarot did not simply call the Trump "The Scales". Perhaps they did not find a suitable word for such a thing in Hebrew that began with the letter "L". One Hebrew word for "scale" or "balance" is PL\$, which begins with a P. A similar root, PLS, has the meaning of penetrate, trespass, or invade and is the name the Hebrews gave to the Philistines (Palestinians). Apparently the Hebrews invaded Canaan and then turned around and called the local people "invaders". Clever politics -- always stick the "bad" labels on the other guy.

These Hebrew roots suggested to me the English "phallus", a word that everyone assumes comes to us from Greek. What if the Greek "phallus" comes much earlier from the Semitic language? What if the Hebrews not only called the Palestinians 'invaders', but they also called them 'pricks'? Invading pricks are rapists. Two other Greek words came to my mind. The first was Pallas, as in Pallas-Athena. Athena was the namesake Goddess of Athens, specializing in wisdom and military skill. In the Goddess Tarot Athena plays the role of Justice, using wisdom to judge and military prowess to punish. The word "pallas" refers to the brandishing of a spear or jerking of a javelin either as a threat or as a warm-up to throwing it. This shaking movement perhaps is related to the word, "pulse", an intermittent beating or throbbing. The Greek term was also used to refer to the shaking of a helmet to choose lots. It then came to mean the protruding top point of the helmet where the fighter attached a feather. Such jerking and shaking motions are characteristic of the penis in action. Perhaps spear shaking and saber rattling were slang expressions for masturbation.

The other word that came to mind was "Philos", which means "love". The Hebrew word for heart is LB, a word obviously related to "love". So there seemed to be a cluster of connections in this root to love, military skill, and the male generative organ. L is the central letter of the Hebrew roots PLS/PL\$. The letter adopted for the sound "L" in Semitic probably derives from earlier pictographs of scales. A glance at the pictogram of the Scale also convinced me that, turned on its side as it is even today, it becomes a drawing of an erect phallus.

So what does the "Teaching" of Justice have to do with a phallus? The traditional Trump shows a lady dressed in robes seated on a throne. In her left hand she holds the

"Scales of Justice", and in her right hand she holds an upright sword. This image has become the icon for Justice and commonly appears in association with courts of law. Sometimes the lady is blindfolded to show that she is supposed to be truly impartial in meting out justice. The Scales seem to stand for fairness to both parties in a dispute, and the sword then must stand for punishment of the guilty. Certainly the job of the military is supposed to be to capture, kill, or otherwise punish invaders and other types of evildoers. I began to wonder about the whole symbolism of this icon and what it really meant.

The sword and most other weapons such as knives, spears, and modern guns are phallic symbols. They are tools used by men to extend their power and show off their virility by dominating others. If our hypothesis is correct, the letters that spell the Teaching (FW∇ = LMD) contain the male phallus and the female pudendum with liquid (see M) passing between them. This suggests sexual intercourse. Could "The Teaching" be the secret of how to have a good sex life? What is the secret of a good sex life? Assuming that both partners are healthy, it would seem that sex should be something that both parties enjoy fully. We can trace most of the social problems humanity faces back to difficulties in the bedroom. Men have usurped most of the power in society and tend to put females in a subordinate position. We do not have a balanced equality between the sexes. In some societies women are even treated like chattels and lack normal human rights let alone justice. In sexual relations men commonly want to get their satisfaction quickly and tend to give less attention to the needs of their female partners. Consequently women, who often are less rapidly aroused sexually than men, tend to have less fun with the act of sex and often do not even achieve orgasm. Perhaps the Scales that Athena holds in her hand are really the male genitals. The Trump is telling us that in order to achieve fairness in intimate relations the woman must hold the phallus and control its motions and access to her Temple.

The judicial systems currently practiced in the world are sorely out of balance. They prescribe a rule by law or decree. If someone breaks the law, the state administers rigorous punishment in the form of incarceration, physical abuse, or even execution. Some of the supposedly most democratic and civilized countries have the largest prison populations per capita. A common characteristic of prison life is prevention of normal sex life. The result is rampant perversion of sexual energy. Even outside of prison the social structure is such that people often find it very difficult to satisfy sexual desires in 'socially acceptable' ways. This leads to the commercialization of sex and a huge sex industry, both legal and illegal. Something that is a natural pleasure in life becomes an exploited commodity. The result is widespread frustration, disease, and social oppression. People who are sexually frustrated turn to drugs and other forms of amusement, much of which becomes labeled antisocial. The antisocial 'criminals' must be punished, so they are arrested and become prisoners. Execution of prisoners is the ultimate sexual game in the annals of Bondage and Discipline, Sadism and Masochism. In other words the entire justice system in today's society is a perverted sex game. Governments ask the population for large handouts of cash so that they can practice kinky sex. If you do not fork over the cash, they simply expropriate it from you anyway -- at gun-point if necessary. The players in the establishment are deeply addicted to the

justice system. The problem with the addiction is that B&D party games are fun but not very realistic. To make things appear 'real' you must convince someone to really play the role of victim. To do this you set things up so that someone "breaks the law", and then you arrest them and carry out the fantasy game of "Justice".

In an enlightened civilization the Justice game works quite differently. Harry Palmer ("Enlightened Justice Procedure", *Avatar Journal*, 14:4, 2000) describes such a system. An enlightened justice game requires the growth of integrity in the individual. When you recognize that you have publicly or secretly transgressed against someone else, then you stop such action, repent, confess to the injured party or at least to someone, make amends, and then readjust your life into a more balanced, intuitive direction. Notice that Palmer's approach does **not** involve any punishment. However, it does seem to require the assumption of personal responsibility. This, of course, is the flaw in his system. It does not work unless the perpetrator of a transgression willingly recognizes and takes responsibility for his or her actions. So to get a society to that level of Justice will require uplifting people to a level of responsible integrity where they are willing to practice personal Justice in a conscious, deliberate manner. Perhaps we will have to invent a clever game that will tease people into discovering the value of integrity. It will have to be a game that really captures people's attention -- like a really fun sexcapade.

The Sword held aloft by the Goddess of Justice is also one of the four suits of the Lesser Arcana. The Sword cuts through the air and divides things. It represents the mental quality of the Will that can make decisions. Wise King Solomon once decided a famous court case with a sword. Two women came to him to settle an argument over custody of a child. Each claimed to be the mother. In those days there was no DNA testing, so Solomon came up with another solution. He ordered a soldier to slice the baby in two with his sword. Since each woman claimed to be the mother and there was no hard evidence to prove either claim, each would get half a baby. What a fair solution! One woman immediately offered to save the baby's life by giving up her claim. Solomon then awarded the baby to that woman, saying that her love for the baby proved that she was the real mother. We see in this story the interactive balancing act the sword and love, phallus and philos, both play in the Justice Trump.

The organ for the Justice Trump is the male penis. The large posts on the Throne of Justice remind us to invert the card and put attention on the lower half of the body. But the female clitoris and vagina of the High Priestess is its companion Trump, as the name LMD reminds us. Sexual equality means that the woman gets the as much satisfaction as the man. Because she bears the responsibility of carrying a child through pregnancy, she must be given the 'upper hand', so to speak. But this does not mean she should withhold satisfaction. There's more than one way to rattle a sword.

In ancient Egypt Ma'at was the goddess of Justice and Truth. She is the prototype for the use of the Scales as a symbol of Justice. On her head she wears a feather like Shu. This shows a subtle connection to the breath of Life and the element of air. The feather is the counter weight to the heart in the Weighing ceremony. This suggests that when we live our Truth the heart is as light as a feather.

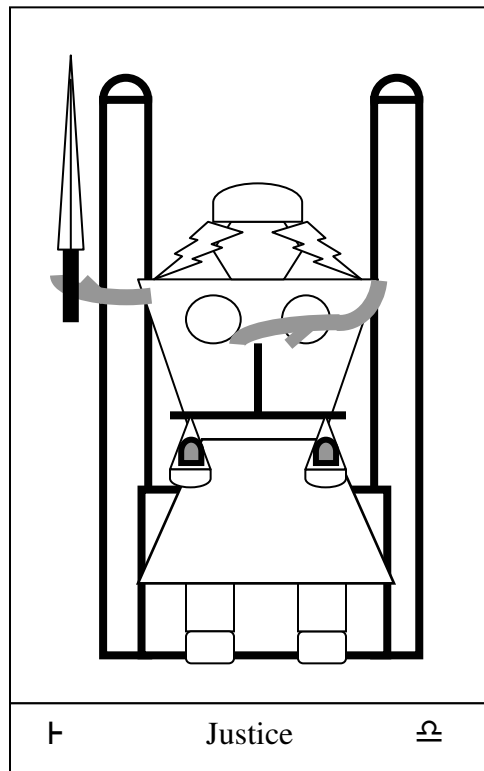
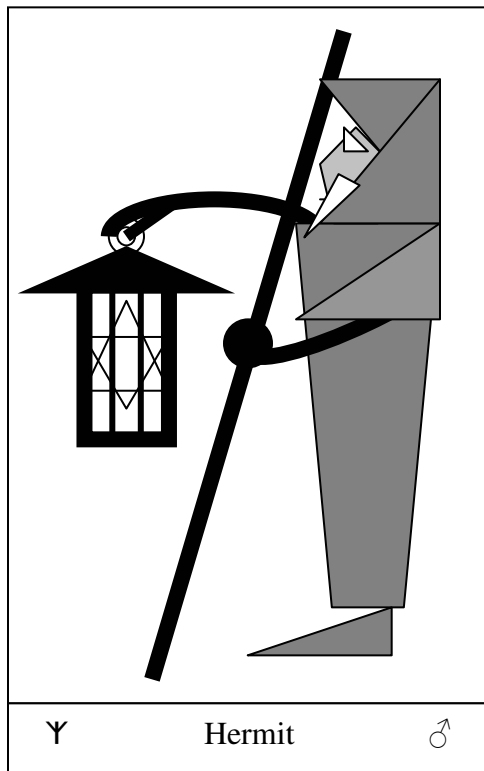
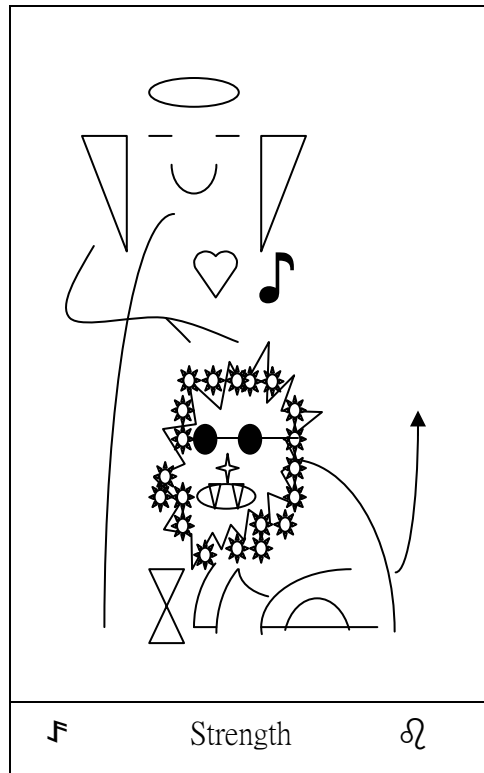
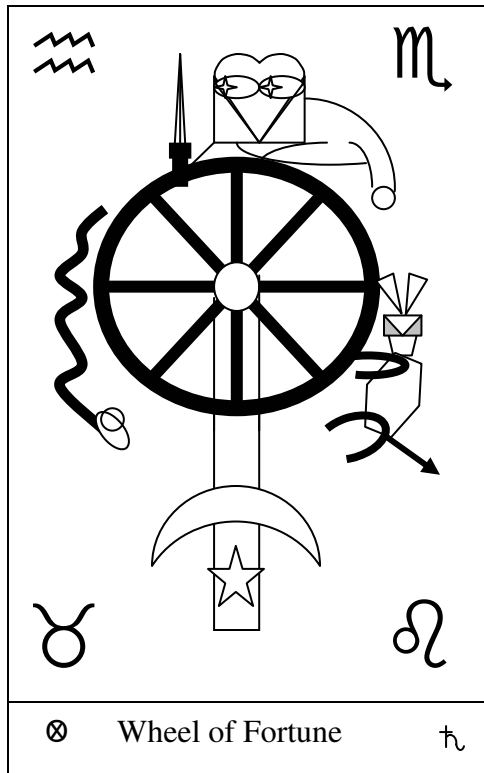

13. Moon (W). The thirteenth letter is **Mem** (Hebrew number 40 and Greek letter Mu M, μ). The Moon Trump actually means "waters". The Hebrew name should be written **WFW**, the Hebrew word for waters. The body's main waterworks include the kidneys and bladder, the circulating blood and the downward flowing urine. The moon is a symbol of the crescent-shaped pubic bone that guards the bladder as it stores urine. This area of the body is also the location of the second chakra, the seat of sexual drives and many emotions. The moon strongly influences the earth by controlling the tides, a nice symbol for the ebb and flow of body fluids, emotions, and also the current of time. Our memory of the past comes from Mem. Life originally evolved from the water in the ocean, and even today the body is mostly made of water. So the Moon Trump is a potent symbol of deep-rooted physical and mental patterns we have built around the ingestion, movement, storage, and excretion of water. The monthly menstruation period of every woman ties in with the daily flow of urine. Blood and urine are the two major forms of water that flow through the body.

Traditionally we use two types of calendar for recording the flow of time, solar and lunar. The solar calendar is useful for agriculture, and the lunar calendar is useful for fishing, animal husbandry, and family planning. The Lunar Trump thus also deals with traditions, past lives, patterns of social behavior and feelings. The lobster (or crab) is an artistic device to show the influence of tides. You can not draw the changing tide in a still picture. But you can show a crab on the beach at low tide. The crustacean also suggests blood with its reddish color. The dog and the wolf howl at the moon to show her influence on their emotions. A yellow path winds up into the mountains suggesting the winding path of evolution from the past to the present. It also is the urinary tract. The two towers remind us that this Trump deals with the lower part of the body. We must invert the card and discover the proper location of the bladder relative to the legs. We then see the ureter leading down from the bladder to the mons -- the mountain in the background. The two furry canines baying at the moon suggest the patches of pubic hair on each side of the pudendum with the urine trail passing down between them. The lobster represents the menstrual flow mixing in with the urine.

Unconscious patterns of personality take shape in the first two years of life, the period of nursing. The Nurse Goddess, Renenet ("Namer") is the Moon Trump. Behind and above her is Thoth in his form as Khonsu, the Moon, protecting the child from crocodiles and scorpions as he lives through the cyclical patterns of his life. The Nile scorpion is the Egyptian "crab" or "lobster". Isis hid in the papyrus swamps of the Nile delta after Horus was born because she knew Set would try to kill him to prevent him from seeking revenge for killing Osiris. Set sent poisonous scorpions to kill the child, but Thoth neutralized the poison and turned the killers into harmless Nile scorpions that baby Horus played with as toys. Thus Serqet, the Scorpion Goddess, becomes another form of the Nurse and an alternate form of Isis. The two dogs are Anpu, Lord of Death, and Up-Uat, Guide (Opener of the Way) through the Tuat. Each sits on a mastaba tomb. The nurse starts the baby out on the path of life, giving him her milk and changing his diapers. She also teaches him his name and the basics of speech. Anpu waits to meet the baby at the end of his life, and Up-Uat conducts him through the Tuat to begin his next life. Beliefs from the past that we do not experience fully will shape our future life events.

14. Star (♄). The fourteenth letter is **Nun** (Hebrew number 50, Greek letter, Nu N, ν). The Hebrew letter has the meaning of a "dwarf" (NaNa\$). NYN is a descendant or grand-child. NUN means to waste away or deteriorate. It seems to indicate something small or something that shrinks. (Nun was also the name of Joshua's father. Perhaps Joshua's father was a very short man.) In any case the stars are very small compared to the sun even though it turns out that they are also suns, and many are even galaxies consisting of millions of suns. So the idea expressed by the Star Trump is that there can be something quite small that is very powerful and influential. The ancients believed in astrology. Even today astrology remains extremely popular. The theory behind astrology is that the movements of the planets among the stars influence our lives and even determine our personalities and experiences. Whether or not this is true does not matter. If people believe it to be true, it will strongly influence their lives. Also we know that the ancients studied the stars so as to understand and predict the changing seasons. They also used the stars for navigation. The Phoenicians, developers of the alphabet, were intrepid mariners who navigated by the stars. Camel caravans crossing the trackless deserts navigated by the stars. So the stars are small but can powerfully influence our lives.

In the foreground of the Trump card we find an important clue to the icon's relation to our physiology. A nude lady with very long hair pours libations from two urns. She pours a libation from one pitcher onto the land, and from the other pitcher she pours into a pond. Do the two pitchers represent the intellect and the intuition? The libations may consist of wine, oil, milk, honey, or other liquids. The naked lady is performing the ritual of puja, a sacrificial libation for purification and reunion of the individual with nature. In our body small organs called glands secrete tiny amounts of special substances called hormones that manipulate the level of excitation of various bodily functions. Each of the chakras has a gland associated with it. Thus we find a star on the card for each chakra plus a large star for the brain -- the Sun. The gland-pitchers may hold various hormones such as adrenaline, epinephrine, thyroxin, and so on, but they also produce the sex hormones testosterone and estrogen, and the endorphins associated with pleasure sensations in the brain. The woman's full frontal nakedness suggests her potent sexuality, and her ritual is an intention to be in tune with the flow of Nature.

In the background is an ibis. The BOTA version of this Trump shows the ibis perched on a tree. This is very odd and strikes the attention. The ibis is a wading bird. I have only seen ibises wading around in the reeds at the edges of lakes and ponds, never perched in a tree. If the ibis reminds us of Thoth, then the tree reminds us of the Tree of Life. The eight stars plus the two jars give us the ten sephiroth of the Tree of Life. Some cards show a flower with a butterfly instead of a tree with an ibis. This suggests the Flower of Life and its transformation into the Tree of Life in the cycle of Nature.

The ancient Egyptians called the primordial flux of pure energy out of which the cosmos takes shape Nun. This is what modern physicists call the Vacuum State of all possibilities. In English NONE represents the primordial condition and carries on the ancient Egyptian tradition. The nude celebrant may even be a nun of nature. The Egyptians illustrated Nun graphically as a god filled with wavy energy lines and wearing

a headdress made of three pots balanced on the sign for heaven (Pet). In one hand Nun holds the ankh, symbol of life. In his other hand he holds the tcham, a lightning staff of electric power. Nun is the primordial form of Hermes Trismegistus, the archetypal alchemist. The three pots are the three realms in which Thoth-Hermes operates -- action, thinking, and pure being. They are the three pots used by the alchemist to hold the ingredients for creating gold -- mercury, sulfur, and a type of salt. The alchemist himself is made of water. The alchemical process is an electrolytic low temperature transmutation that has various levels of interpretation -- literal, allegorical, metaphorical, anagogical. Each of the ingredients is actually in Heaven always, but Thoth ("below") as Nun ("none") appears to walk below heaven, wearing Heaven on his head like a crown. Ironically he is "below none". The sign called heaven (pet in Egyptian) resembles a tray or a bracket. This is what the Hebrew Torah calls RQYO, the firmament. The firmament is a funny lens that distorts the reality of higher spiritual consciousness into the physical appearance of Life. (There is a strange camp movie about the illusion generated by the RQYO. It is called "The Rocky Horror Picture Show" and appears to be a musical based on a bizarre retelling of the Frankenstein story. Watch it sometime and see if you can figure out what is going on.)

The energies of Nun become the waters of the firmament. Later in the creation process Nun transforms his possibilities into potentials as Atum (atom/Adam). Then, with the assistance of Love (Hathor) he masturbates to generate Shu and Tefnut, who then beget Nut, the night sky sprinkled with stars and Nut's male consort Geb, the Earth. So the starry night sky of Nut is connected to the primordial energy pots of Nun, and all of this finds its way into the Hebrew letter Nun. The powerful creative energy of life becomes the scattered seed of Atum that we call stars and the Milky Way spread across the night sky. Nut reminds us. The universe is not vast. We have shrunk, and our minds are tiny.

The importance of sexual potency in this Trump is enhanced by a subtle reference to the story of Abraham, the first patriarch of the Qabalah in the Jewish tradition. Abram (AB-RM, or "High Father" as he was originally called) was very learned and successful in many ways, but he lived to be very old and remained childless. His wife Sarai (Princess) worried that he was impotent, so she let him also try to beget a child with Hagar, her handmaid. Hagar conceived right away and gave birth to Ishmael ("God has heard"). This evoked Sarai's jealousy. She realized it was her womb that was barren, not a defect in Abram's seed. So in her frustrated anger she regretted her former generosity and mistreated Hagar. Abram still wanted to have a legitimate child by his wife. So God made a covenant (Genesis 17) that ensured Abram would have descendants as numerous as the stars in the sky even though Abram was already 99 years old by this time. The usual interpretation of the condition of the covenant was that Abram would institute the custom of circumcising every male child within eight days after birth. Abram, taking the agreement in this way, circumcised himself and all the male followers in his band, and subsequently fathered a son by Sarai. This son was Isaac ("Shouted [with joy]") the father of Jacob (Israel), the progenitor of the Twelve Tribes of Israel. God then told Abram and Sarai to change their names to Abraham and Sarah. The insertion of the letter "H" into their names shows that the breath of life has an important relation to sexual potency. Abram became Abraham ($\forall \square P \text{ F} \text{ W} = \forall \square [P]$)

𐤀𐤍𐤏𐤍 = AB[R]-HMUN: A Father [Leader] of Multitudes). His original name actually also had this meaning 𐤀𐤁𐤓𐤀𐤍 (ABR-AM: Leader of the People or Nation). ABR is the Egyptian god Apis, a bull-god, symbol of procreative power of the Sun, the power of the Father, and the letter A. He is the bull consort of Hathor.

A curious myth has grown up around Apis that speaks of bees making their nest in the bodies of sacrificed bulls and producing fine honey. Thus even today a bee farm is called an apiary. This story comes up numerous times in the ancient myths and connects the Star and Sun Trumps to Strength. Samson killed a lion, symbol of the sun, with his bare hands and later found honey in the lion's corpse. Samson ("Little Sun") was famous for his physical prowess and sexual potency. He was a NaZYR adept, and, like the yogis of India, never cut his hair -- an unpruned vine. This was part of the secret of his power. (Notice the woman's long uncut hair in the Star Trump. She is also a NaZYR. Jesus lived in Nazareth, a place named after the Nazys.) The Bible story contains a pun on the expression "swarm of bees". This phrase also means "the letters of speech". The secret of the Tree of Life lies in its hexagonal geometry. Bees use this same geometry to make their honeycomb. Virgil has a Georgic on apiculture in which he tells the story of a shepherd who has lost bees and must do a bull sacrifice to get them back. The swarm of bees that lives for eternity is the stars in the sky and the letters of the alphabet. God called his covenant with Abraham a "sign" (or letter of the alphabet.)

Although Sarah forced Abraham to expel Hagar and Ishmael from the family, they survived to become the progenitors of important Arab tribes. Rivalry between the Arabs and the Jews stems in part from issues going back to the patrimony of Abraham.

The ritual of circumcision is a gross misinterpretation of the intention of the so-called "covenant". There is no way that removal of a man's prepuce enhances sexual potency. It is in fact a cruel and unnecessary act, whether imposed on a newly born child or an adult. Clitoral circumcision is an even crazier custom that has been used to suppress female sexual pleasure. Female circumcision seriously violates the canon of Justice. The actual intent of Abraham's covenant, as far as I can tell, was to encourage the young members of the tribe to become sexually active as soon as they reached puberty. This would ensure lots of pregnancies and therefore lots of descendants. The expression "on the eighth day" should be read as "the day when semen ejaculates," in other words, at puberty. The word for circumcision should be read literally as "bloody the penis" (ML). To interpret this as cutting off the foreskin is a misunderstanding of the natural meaning of the two letters, although that is the cruel way in which Jews have interpreted it for countless centuries. A more reasonable interpretation of the covenant suggests that a boy at puberty should have sex with a pubescent virgin. Parents should not try to stop their children from having fun exploring their sexuality. Encourage them to play with it and have great natural and innocent sex. When a boy breaks through his girlfriend's hymen during their first sexual encounter, his phallus will be smeared with a few drops of blood. This is a rite of nature that does not hurt anyone and will ensure normal sexual potency and many offspring.

The ritual circumcision of men (and women) over the past several thousand years has

caused terrible pain and suffering in the world. What a way for a boy to enter the world! First they spank you, and then they cut off the front of your penis! The ancient Jewish warriors who had already been circumcised used to cut off the foreskins of enemy soldiers that they killed. They took the foreskin as a war trophy and proof of "manly" victory. You ritually insulted your enemy's body and proved that you had not just stripped trophies from your own dead soldiers like the violent coward you were. When David asked to marry Saul's daughter, Saul made David buy her from him with the payment of over 200 foreskins collected from the bodies of murdered Philistines. It is no wonder that the Palestinians do not exactly welcome the descendants of David to move in, expropriate their land, and become their neighbors.

The ancient Jewish warriors carried the foreskins they collected from their enemies in little leather boxes called tephillim that they strapped to their arms. To protect themselves against the ghosts of their dead enemies they wrote magic prayer formulas on the foreskins and recited them while holding or strapping the little box over their third eye. This ritual persists even today among conservative Jews, although they no longer write the prayers on the foreskins of their enemies. They still use the tephillim and write the prayers on strips of leather, parchment or paper instead of foreskins. They also still continue to practice the circumcision that they believe "God" commanded them to do as part of the "covenant" to achieve sexual potency.

The Star Trump card usually depicts eight stars in the sky. This is the number that God seems to mention in his covenant with Abraham when he says: "He that is 8 days old shall be circumcised among you, every male." [Y-⊠Y WWYX FWFW FWYF FYW YF ZYP U-BN SMNT YMYM YMUL LKM KL ZKR. (Gen. 17:12)] The number 8 in Hebrew is WWYF. The phrase SMNT YMYM "8 days old" should be parsed and read as WWYXF WFW = ShaMeNeTY MaYiM "creamy waters", an obvious reference to semen, the Milky Way sperm of Atum/Adam. ShaMeNeT is cream. MaYiM is water. The whole phrase should read: "And when every male son has creamy waters (i.e. begins to ejaculate semen), let him bloody his penis [by penetrating a virgin.]" The libations that the woman pours probably are essential oils based in olive oil. SMN is olive oil. Our word "semen" comes from the same root, SMN. She may be a virgin performing a ritual ablution before undergoing the sacred ritual of giving up her virginity to her lover for the perpetuation of Life on Earth. A variant spelling \$MN means a mark or sign. It can also refer to stars, since a constellation was known as "a sign in the stars" (\$MN B-KUKB). So here we see the connection between stars, letters of the alphabet, and the gonads. The sky is like a book to a scientist or a navigator. The 22 letters of the alphabet spread across the sky as the 12 signs of the zodiac and the 7 planets plus heaven, earth, and man. And the Milky Way flows through them all with its countless stars reminding us of dark-skinned Nut filled with the Gift of Geb, the original seed of Atum/Atom/Adam.

Nut's pot is also the initial letter of her name, a form of the letter N in Egyptian. The letter N also symbolizes the **NOSE**. Many glandular secretions specifically stimulate the sense of smell. This includes sweat and various pheromones and special odors that guide our sexual preferences and our attraction to food.

15. Empress (𐌺). The fifteenth letter is Samekh (Hebrew number 60). The Greek letter is Xi (Ξ, ξ), but its name is Sigma. The two "S" letters in Hebrew got twisted when they became Greek letters. This is not surprising because the pronunciations of the two letters are so similar. Local dialect differences easily blurred the distinctions. The Greek Xi consists of the three horizontal lines of Samekh. The Greek letter Sigma (Σ) is just the Hebrew Shin (ש) turned on its side. The pronunciation also changed due to metathesis: Samekh --> Sigma. The pictogram chosen for the letter shows a staff or tool of some sort. The name means a support. The Empress supports the Emperor and serves him as his helpmate. She is the Shakti energy of the body. The Shiva energy of the body rides in the breath of the lungs, and the Shakti energy rides on the eggs in the ovaries. The Empress has a matronly look and wears a long flowing dress. In many Trump depictions she sits or stands in a garden park surrounded by roses, ripe grain, a grove of trees, and a stream. The feeling she conveys is one of fruitfulness and abundance. Life flourishes under her influence. She holds in her right hand a heart-shaped shield (love) with a dove (peace) on it. In her left hand she holds a scepter topped by an orb. Her left foot rests on a crescent moon, the symbol for the pubic bone, indicating some connection with that part of the anatomy and connecting her to the High Priestess. On her head she wears a tiara adorned with twelve stars. This naturally connects her with the Chariot and the Star Trumps. The twelve stars are the signs of the zodiac. The Empress of the human body is the ovary. The stars on her tiara are the eggs that she carries to plant in the womb as the possibility of future life, the twelve sons of Israel and their countless descendants.

The letter Samekh in its old pictographic form resembles the patriarchal cross staff carried by the High Priest. The sacrum is the triangular bone found at the base of the spine directly behind the triangular pudendum. The ovaries are located just above and behind the sacrum. In the BOTA version the Empress has a triangular insignia on the center of her chest. Waite shows the Empress bearing the symbol of the planet and Goddess Venus on her shield. This is the Ankh. Often you see it topping her staff.

The name for this letter goes back to Sekhmet, the Lion Goddess, a form of Hathor. The Lion is the animal symbol for the sun's energy. The lioness is the sun's consort, his Shakti. She is the wild Life Energy that survives and evolves on the planet. This Trump relates strongly to Sekhmet, but really stands for Hathor, the daylight sky that embraces the sun. Cow horns are rays of light. Ra, the sun high in the sky is also known as Horus the Elder and as such takes the form of a hawk floating high in the sky. This became the eagle emblem of emperors. The atmosphere god, Shu, wears a feather of Ra on his head to make the connection between sky and sun. He captures the sun's rays and brings the power of Ra to earth where it becomes embodied as the emperor. So the Emperor Trump often shows the imperial eagle emblem. This is also the heavenly sign of Scorpio, indicating the emperor's power and responsibility over life and death.



Het-Heru, House of Horus (Hathor) The Empress often bears a shield with the imperial eagle, glyph of Hathor.
Examples: Visconti-Sforza, Brugel, Wirth

16. Magician (O). The sixteenth letter is Oayn (Hebrew number 70 and Greek letter Omicron O, o). Omicron means "little o." The Hebrew name for this letter refers to the "eye". The original Egyptian pictogram of an eye has been simplified to become a round circle. The Egyptian glyph, pronounced Ar, was a detailed picture of the eye showing the eyelids and the **iris**. This is the glyph used in the name of Osiris: Ash-ar. The "Ash" of the name is the same as the Ash in his consort's name, Ash-t (Isis) and means "throne". So Osiris is the Eye over the Throne. The Magician's table serves as his Throne in this Trump. Note that the Egyptian glyphs are usually written in reversed order, with the eye first (but the eye is below the throne in the Pyramid Texts). The name Osar in Hebrew transliterates to O\$R, or OSR, or A\$R, or A\$R. O\$R (O𐍆P) is not in the dictionary, OSR (OWP) means ten or wealth, A\$R (𐍆𐍆P) means prohibition or to imprison, and ASR (𐍆WP) means happiness or luck and is also the name of one of Jacob's sons. There is clearly a connection between ASR and OSR. The two letters, A and O, have very similar sounds and sometimes interchange, just like S and \$.

Compare the Magician Trump to Strength, and you will find the same infinity nimbus halo over the Magician's head that you see over the Strong Lady's head. In our astrological list we find that the Magician stands for Mercury, also known as Thoth or Hermes. The Magician's eye surrounds his head as a headband, limiting his mind. The girdle at his waist is Ouroborus biting his own tail. He is the cosmic serpent (Apep) who swallows the Sun, and even swallows the whole universe. The Magician's eye is the boundary that defines the universe. But over the Magician's head is the Eye of Infinity that looks straight up at the Higher Self. He has no limitations as to what he can do with his creative energy. His right hand holds aloft a Magic Wand, and his left hand points down at the Earth and his throne-table, on which we see the four symbols of the Minor Arcana suits, representing Earth (Pentacles), Air (Sword), Fire (Wand/Torch), and Water (Cup). "As Above, So Below," says Hermes Trismegistus in the Emerald Tablet (see p. 266.) The Magician has mastered the skills of transformation and transmutation of the various elements to perfectly match his Aware Will.

Roses and lilies also decorate the card. The roses show he is a master of the permutations of the alphabet, a master of language. The redness of the roses indicates the ability to manifest speech as living reality. Red is the color of living blood. The lily is the symbol of Love and white is the color of purity. The Eye of the Magician is the Eye of Osiris, the Eye of Horus/Ra, and the Eye of Thoth/Hermes. The planet Mercury is like a little eye floating above the Sun. It is the closest to Source it can get and still maintain a tiny identity as a planet. The speed with which Mercury is famous as the "Messenger" of the Gods is due to his proximity to Source. He accomplishes all tasks easily, effortlessly, and speedily -- as if by Magic. The Magician's Eye is the Eye of his Wisdom Intuition that always shows him what the next proper move is. Thoth is the Magician who opens that Eye of wisdom for Osiris and all aspirants.

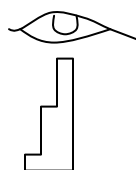

AR

= ASAR = Osiris (OWP)

AS

Secret Sign of the Cobra Technique

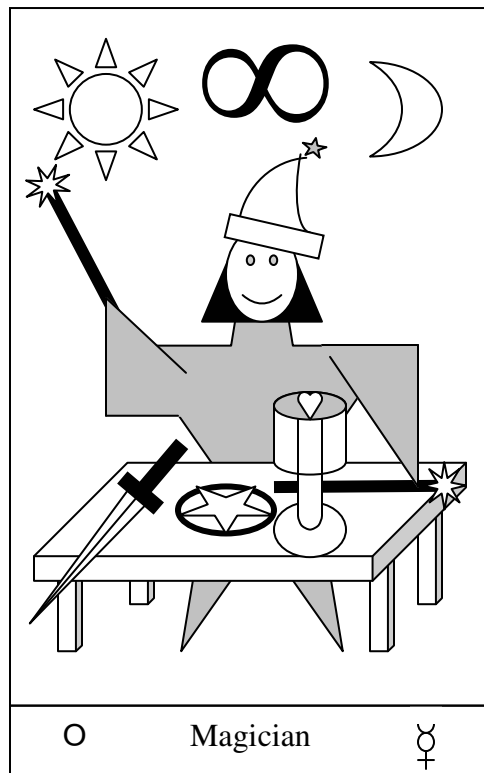
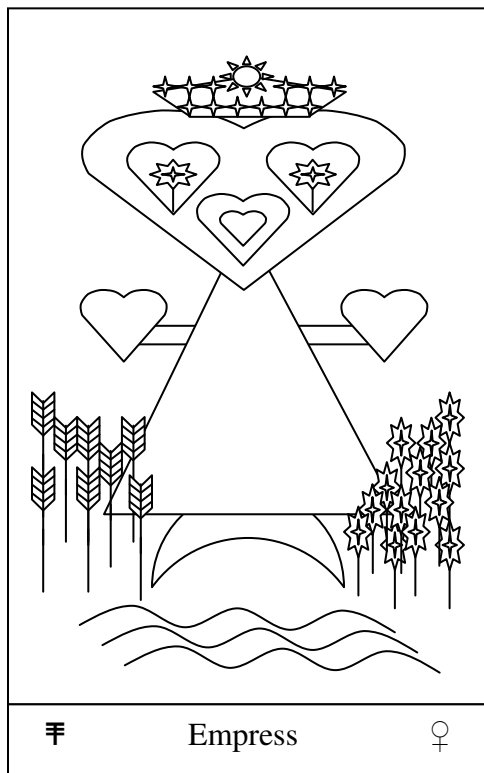
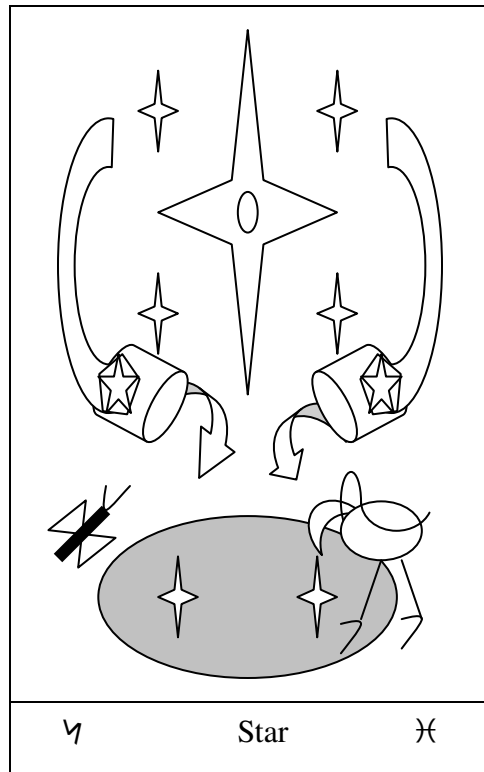
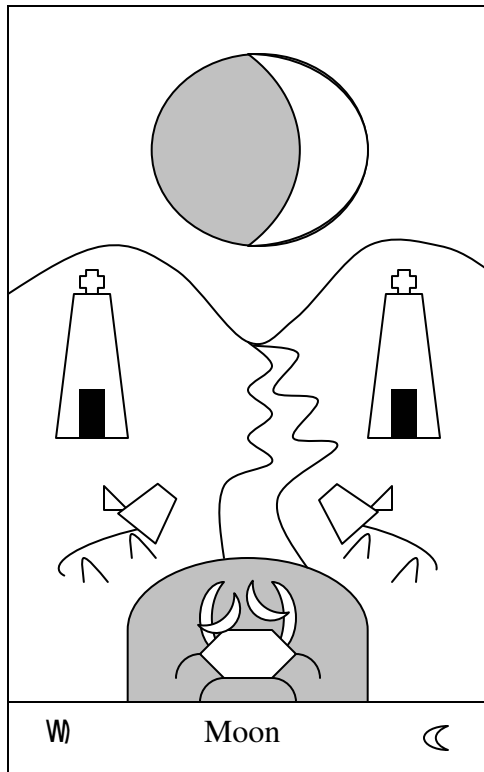

17. Temperance (7). The seventeenth letter is Peh (Hebrew number 80, Greek letter Pi Π, π). This is the mouth. The pictogram shows the mouth from the side view because Oayn already uses the circle glyph for the eye. Temperance is an obvious meaning for this letter, since we need to exercise moderation in what we eat and drink as well as what we say and do with our mouth. The proper icon of the Trump shows an angel pouring a liquid from one pitcher into another. Like the Star Lady he often has one foot on land and one foot wading in the water. The key image on the card is the mouth of the jar. The liquid goes out one mouth and into another. This shows that the mouth is a two-way portal. An obvious implication here is kissing, an essential part of the foreplay (and main action) of lovemaking. The anus is another "mouth". For some people the notion of "kiss my ass" brings up the idea of Temperance. The BOTA version of this Trump shows the element of fire represented by a torch and/or a volcano. When fire predominates, it boils water. When water predominates, it extinguishes fire. Cooking is a balance of fire and water to produce food. There apparently is a connection between Temperance and Justice. We even hear people speak of tempering justice with mercy, although to my mind that sounds like double-speak. The implication behind the word justice is that you are guilty as charged, but we will be nice to you if you cooperate. These ideas of Temperance are often as warped as the notions of Justice, so we must tread carefully here. Indoctrination often masquerades as the voice of Temperance under the guise of telling other people what to do because it is for their own good.

The BOTA version of this card also shows two of the Living Beings in the foreground -- the Lion of Leo and the Eagle of Scorpio. The lion represents Sulfur, and the Eagle represents Mercury. This is symbolism of alchemy, suggesting that there is an alchemy process behind this Trump. This links Temperance to the Devil Trump. The Angel of Temperance on the BOTA card has an Åthen solar disc on his forehead. With his huge angel wings that makes him a flying solar disc. His whole head radiates with an aura and there is a rainbow in the background. The colors of the rainbow suggest the energies of the major chakras. As if to confirm this notion we find a seven-pointed star on the center of the Angel's chest. Above it is the Tetragrammaton IHVH. This word in Hebrew comes from the root HVH, to exist. The letter H, repeated twice, is the pictogram for the breath and the lungs. The letters are inscribed right at the point where the bronchial tubes branch into the lungs. The name IHVH thus is a pictographic representation of breathing out (IH = eeh) and breathing in (VH = ooh), the cycle of the breath that keeps us alive and provides the oxygen that is the primary element necessary for metabolizing food.

The Egyptian embodiment of Temperance is Nebt-het. She is Lady of the Palace or Temple or Mansion of All. She is sister to Isis and wife of Set. Like her sister Isis, Nebt-het usually wears her hieroglyphic name as a crown. She is usually very reserved and lets her sister Isis receive most of the attention, and always supports her. When Osiris is killed, she comes to help Isis. The two sisters find his body, repair it, and resurrect it with Thoth's help. She is the Kundalini Life Energy that stays mostly in the background until called forth by the Higher Self to manifest full creative potential. Her name contains a secret yogic mantra and procedure. She offers pots of Soma.

18. Tower (⚡). The Hebrew letter for the Tower Trump is Tzadde, the numeral is 90, and there is no Greek letter for this Trump, since the Greeks did not have this sound in their language. Scholars of the Tarot have fretted to figure out which Trump goes with the letter Tzadde. Yet this is one of the most obvious letters in the Trump alphabet. The Trump's icon nicely matches the pictogram for its letter. TzaD means to hunt or shoot, as in shooting an arrow or a gun. The usual image shows what lightning striking the Tower and knocking off its golden Crown. Oddly the lightning seems to come from the Sun, which should not be visible during a thunderstorm. So this is a clue that the picture really is about something else. Usually we see sparks and flames with people, and sometimes bricks being ejected from the Tower. The people look like they are falling, and one of them usually looks like a king wearing a crown. The problem the Tarot researchers had was that they tried to match the modern Hebrew script for Tzadde (צ) to the Trumps. It does not fit, just like the Oayn (א) has no resemblance to an eye or to any of the Trump pictures. With that approach they were lost. The ancient Phoenician form of Tzadde clearly shows the Tower and the zigzag lightning bolt. Now what part of our body "shoots" and gives off an experience like a lightning bolt? The only obvious physical resemblance I can find is the ejaculation of sperm from the penis. This Trump therefore stands for the sperm, just like the Empress stands for the eggs in the ovaries, and the Star represents the gonads. The sparks and falling people are the individual sperm cells. The people are not really falling. They are future children. If we reverse the card, then we see the people flying upwards surprised to discover that they will now become humans. They are not dying; they are incarnating!

If the energy flows downward to procreate children, the king's crown falls. But a new heir gains life. When we hold the Trump upright, the Crown is at the top, and the Tower reaches up toward Heaven. If we superimpose the Tree of Life on the Tower, then we get the Kundalini rising up the spine to open the Crown Chakra, the Kether Sephirah at the top of the Tree. The suggestion given to us by the Trump is that we can turn our orgasmic energy upward to enliven the nervous system, cellular metabolism, and brain cells, opening up all the chakras and clearing the meridians and marma points. This process can happen very rapidly, even suddenly. With proper techniques such as the Cobra Breath this occurs very naturally, preparing the practitioner for life in the higher states of consciousness. The procreative sexual drive gets transmuted into jet fuel for spiritual evolution. People have a hard time recognizing the irony that their "stuff" -- the issues that are stuck in their lower chakras -- keeps them from opening up the higher chakras. Some deliberate practice to clear the lower chakra issues related to survival, security, sex, emotional charges, and power trips rapidly facilitates personal growth and the ability to experience spiritual love. This is the primary suggestion presented by the Tower Trump -- a spiritual breakthrough. The presence of the Sun in the corner shows that this sudden transformation can bring one into alignment with Source. The drawings often show the lighting arrow coming direct from Source. Sudden terrible calamity may transform your whole experience of Reality into a new life. The Tower is Tem (Atem, or Temu), the phallus of Amen-Ra that creates the whole universe from the bliss of his ejaculation. Osiris attains the state of Atem/Adam. Tem wears the combined White and Red crowns, the coitus of South and North Egypt. On the front of the Red Crown is an upward curling lightning flash of serpent fire..

19. Fool (☿). The nineteenth Hebrew letter is Qoph, and has the numerical value of 100. The Greeks never used this letter. They did not have the sound. But the Romans used it together with “u” to utter “kw” (qu sounds ignoring its characteristic middle-eastern laryngeal articulation) and we retain it in English for some foolish reason, though we do not have the sound either. The organ of the body for this Trump is the tongue. The letter is articulated with the root of the tongue pressed against the throat. The ancient Phoenician pictogram is a bit ambiguous. It can be a face sticking out its tongue, or a tongue licking something such as a mouth, a breast or a clitoris, or even a lollipop. A Fool is someone who does foolish things. He pays no attention to social conventions. A Court Jester deliberately defies conventions and even makes fun of the king. An idiot does not know any better. In either case the Fool knowingly or unknowingly steps into what "sensible" people consider dangerous territory and fails to worry about it. The Waite and BOTA Fools are stepping out onto a tongue of rock without bothering to look down to check the footing. These Fools are pretty young men dressed almost foppishly. They may be gay -- another type of Foolishness according to the conventional wisdom. Other Fools look like vagabonds. Commonly we see their pants falling down, even revealing their buttocks. Accidentally or deliberately he hails the Moon. This type of bare butt buffoonery typifies the Fool. The Fool Trump covers all sorts of weird, kinky, and perverted aspects of Life. The tongue makes Fools of us by babbling speech. It is also a great tool of lovemaking. Even ass-licking and buggering is OK for a Fool.

The Fool usually has a pet animal that tags along with him, sometimes nipping at him, even pulling his pants down. The Hebrew word Qoph means "Monkey". This is the mischievous, fun-loving transformation of the dignified Thoth as Qeftenu, the sacred dog-headed ape. In India this is Hanuman (the Vedic Vrisha-Kapi). In China he becomes known as Sun Wu-kung, master of foolishness and magical transformations. The close companionship between the Fool and his animal also suggests bestiality. The Fool lives with his animal as if it were his most intimate companion. The Europeans did not have monkeys, so they usually substituted a dog, which is fine, because the ape of Thoth has a dog-shaped face. If Thoth is the Fool, then Anubis is his canine sidekick. The dog can be shown panting with his tongue hanging out to match the icon. Some Egyptian-style cards show the Fool treading on a crocodile. The crocodile was Set's Pet. Properly we should see the Qeftenu form of Thoth who jimmies the Scales of Justice, coaxes Sekhmet into returning from the wilds, and manages to keep the crocodile monster Sbek or Ammit from eating people's hearts.

The Fool usually carries a staff slung over his shoulder with a leather satchel tied to its end. This is a symbol of the phallus and scrotum. The BOTA version shows an inscription on the leather bag. There is an eye over an eagle. The eagle is Scorpio, the pineal gland, what we often call the third eye, or the Eye of Horus. Recall that the third ventricle in the brain is shaped like an eagle and is the receptacle for Soma, the drink of the Gods. Qeftenu presents this eye to Thoth. The other eye is below his ass. The Fool may be stupid, but he knows something that most people ignore. By playing with his sexual energy through masturbation or whatever other games he can come up with, he can deliberately channel this Kundalini Life Energy from his prostate up to his brain where it awakens Siva, the pineal gland. The Eye of Horus opens the Eye of Osiris.

When the Eye of Wisdom opens, the Fool sees the world from the viewpoint of Source. Sure enough, right behind the Fool's scrotum bag is the Sun, Source of all Life, the Higher Self. Physically it becomes the prostate. The red feather mounted on top of the Fool's head and pointing back toward the Sun gives us further confirmation. Like a weird cartoon character the Fool sticks his tongue out the top of his head and waves it at the Sun. This is a reference to a yogic mudra known as kechari in which the tongue is folded back in the mouth and reaches up to touch the brain pan. In ancient Egypt kechari mudra is encoded in the hieroglyph for "heaven". There are various secret technologies in advanced yoga that apply this mudra. To the uninitiated such contortions of the tongue look foolish and crazy. But there is method in the madness, as there is in the various strange-looking yoga postures. In the Egyptian iconography Toth's consort, Maat, always wears a feather on her head. This feather stands for Truth. In the Scales of Justice the Feather of Truth is balanced against the Heart. The Wisdom Eye of Intuition opens only when the Heart is as light as a feather. The other Egyptian God with a feather on his head is Shu, the progenitor of Heaven and Earth. He produces the universe by masturbating like a Fool. Perhaps the Fool is speaking out of his crown chakra mouth and conversing directly with his Higher Self. In many cultures the Holy Fool is venerated as the speaker of Truth. He speaks the Truth because he simply does not know any "better".

The left and right Eyes of Horus encode the Egyptian system of fractions: 1/2, 1/4, 1/8, 1/16, 1/32, 1/64. This series when permuted between the two eyes gives mathematical values for all the hexagrams that later became encoded in the Chinese I-jing. We still use remnants of this system in our traditional liquid measures. Toth was fooling around with binary code thousands of years before the Chinese heard about it. The Tekhi weight that Qeftenu jiggers on the Scale of Justice is the origin of the Chinese concept of the Taiji – The Grand Ultimate. In Egyptian art the Foolish Baboon is often shown multiplied into a whole troop of baboons all welcoming the sun as it rises in the East.

Below is the Udjat Eye, the Left Eye of Horus (Sun). The Right Eye is the Moon. The Left Eye is also the Morning Sun, and the Right Eye is the Evening Sun. The Eye of Horus was fragmented by Set. This produced the fractions. Toth (Lord of Khonsu, the Moon) restored the Eye to wholeness by an infinite mathematical series. The sum of the fractions equals 1-1/64. The last 1/64 is supplied by the summation carried to infinity. The limit of the summation is Unity.

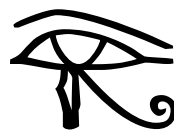

Subdivision of the Hekat:



1/2, 1/4, 1/8, 1/16, 1/32, 1/64

20. Judgment (P). The twentieth Hebrew letter is Resh and has the numerical value of 200 and represents the Greek letter Rho (P, ρ). Resh means "head" or "beginning" in Hebrew. Why isn't this the first letter of the alphabet? It is almost at the end of the list. The pictogram of the letter is usually understood to be a head, though it could be a pregnant belly. Some people associate this letter with the Sun, and this is not completely off the mark. But the brain is clearly the organ that goes with the Sun. A key function of the brain is to make decisions, to make judgments, so there is a connection in there somewhere.

The icon of this Trump shows the traditional idea of Judgment Day at the End of the World. According to tradition based on the Book of Revelations the Angel Gabriel will blow his trumpet awakening all the dead to rise up from their graves. Then God will carry out judgment on them deciding where their souls will go for the rest of Eternity.

Actually the text of Revelations describes seven angels, each with a trumpet announcing a stage at the End of the World. The omnipresent symbolism of 7 in Revelations certainly has to do with the 7 visible moving celestial bodies and the 7 chakra energies. The seventh and final angel sounds his trumpet.

"And there were great voices in heaven saying, The kingdoms of this world are become the kindoms of our Lord, and of his Christ, and he shall reign for ever and ever. . . . And the nations were angry, and thy wrath is come, and the time of the dead, that they should be judged, and that thou shouldest give reward unto thy servants the prophets, and to the saints, and them that fear thy name, small and great; and shouldest destroy them which destroy the earth. And the temple of God was opened in heaven, and there was seen in his temple the ark of his testament: and there were lightnings, and voices, and thunderings, and an earthquake, and great hail." (Rev. 11:15, 18-19.)

Obviously such a scenario is not something that applies every time you pull this card from the deck, just as pulling the Death card does not mean you are going to die right away. The real Judgment is not carried out by God, or an archangel, but by the Self on its Self. You are your own harshest Judge and critic. Whatever punishment you feel you receive in life actually comes from YOU, not from anywhere else.

The organ of the body depicted by this Trump is the womb. In the lower center of the image we see a child rising up out of his grave. The grave is the tomb-womb. The baby emerges from the womb headfirst. So the emergence of the head is the start of life as an individual person. Before that the baby is in the womb attached to the mother. But just as drawing the Death Trump does not mean you will die right away, encountering the Judgment card does not necessarily mean you literally will have a baby. Every thought is a creative act. Every decision, however trivial it may seem, creates a reality on some level of creation. Sometimes it may not seem very manifest, but given time, it will mature and blossom into a full-blown experience. Therefore each thought is our baby. Each intention, each decision, each action creates a "baby" that becomes our future life. Even thinking a thought puts you into that experience in the moment. We usually just do not believe the thought enough to make it a persistent reality. Thoughts

that we habitually put attention on become the reality we live in. Therefore this very important Trump of Judgment invites us to shape our own futures by managing our attention and creative thinking. The trade-off of Judgment is that by putting the attention into the boundaries of a creation, we may limit the possibilities we can experience. We make a choice, and, as a result, may abandon an infinite number of possibilities in exchange for a small selection of experiences.

On the other hand, people who do not exercise Will to make Judgments and do not open themselves up to experience Source are as if dead and buried in their graves. Corpses do not make decisions. Therefore people who prefer not to make decisions and pass the buck to other people instead end up living lives not much different than corpses. They are dead before they are dead. So the message of Judgment is to wake up and create the life that you prefer.

The Egyptian version of this card shows Meskhent, the midwife goddess of birth who assists at the arrival of babies. Above is the image of the baby birthing. Meskhent reaches out to the its perched on its mastaba tomb. The ba-soul has the head of a man (tep) and the body of a hawk (bak). The human head indicates a primary purpose for that individual's life. The winged body indicates the ability to fly over all obstacles to reach that goal. Below the name of Meskhent is a lion-shaped bed suggesting the birth of a royal hero..

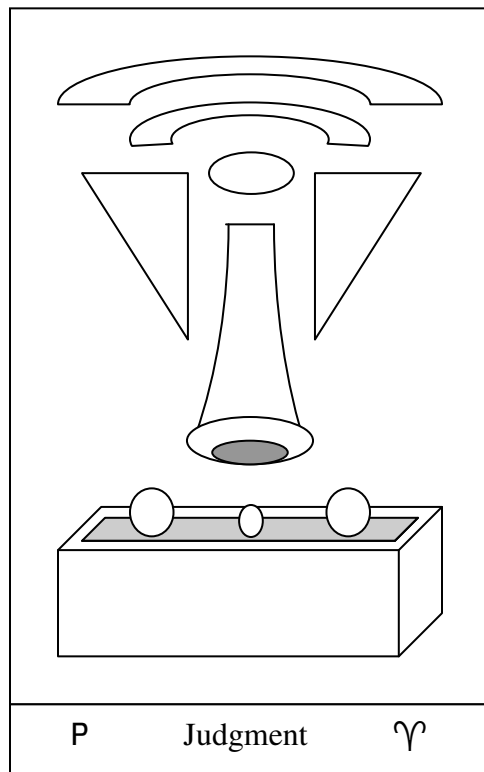
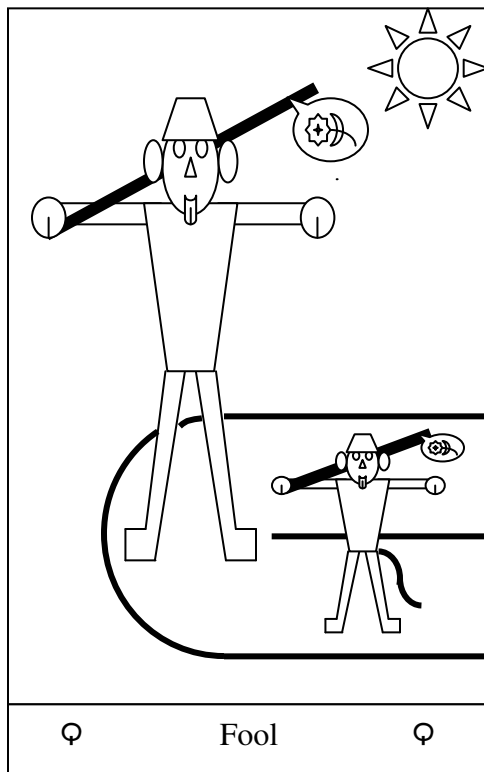
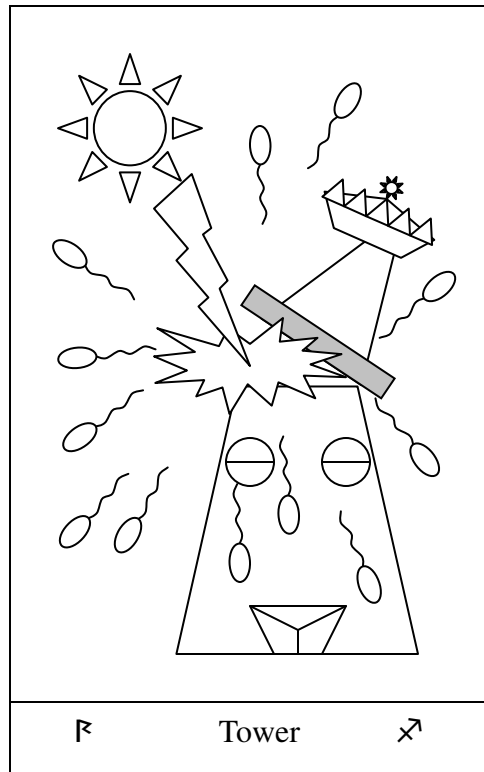
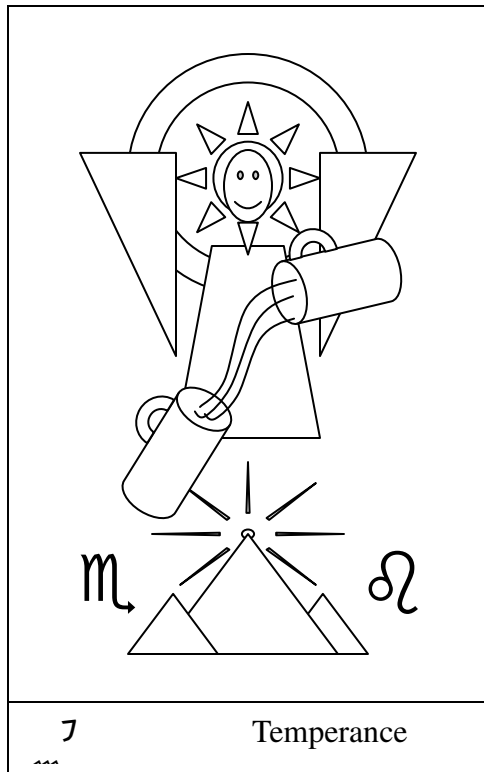

21. Devil (W). The twenty-first letter of the Hebrew alphabet is Shin (numerical value 300). The Greek name for this letter is Sigma (Σ , σ) which is a mistake for the Hebrew name Samekh. The name Shin becomes the Greek letter Xi. The Greeks mixed up both the graphics and the names of these two similar letters. In Hebrew Shin means the teeth. The pictograph shows a pair of sharp teeth such as the fangs of a serpent. But the teeth are only the outer component of this Trump's organ, the stomach. Actually we have here the whole digestive system from the teeth to the esophagus, stomach, duodenum, intestines, and colon. The purpose of the digestive system is to break down food into amino acids and other nutrients that are then absorbed through the intestinal walls into the blood and carried to the cells for nourishing our growth. The Oswald Wirth deck clearly shows this function with tattoos from alchemy on the Devil's arms. The right arm says, "solve," (dissolve). The left arm says "coagula" (coagulate). In other words digestion breaks down into solution the plant and animal tissues that I eat, and then reforms them into cell structures suitable for my body. Over the lower belly of the Devil is the sign of Mercury, the symbol of Hermes, the alchemist. The biological alchemy goes on mostly in the belly.

The Devil has a goat's head with horns and an inverted five-pointed star (pentagram) of Magic on his forehead. The Devil's body is sometimes androgynous, and almost always chimerical -- that is, made up of various animal parts, including bat's wings, bird claws, snake scales, and so on. This may be a pun on "chemical" and also suggests the variety of food sources that we omnivores eat and then convert into our one body. It also suggests the varied shape of the digestive tract itself. The sign of Capricorn Υ starts out with a tooth-like sigil and then turns into a twisting snake that suggests the intestinal tract. The Devil also usually holds a torch or other fire symbolizing the burning process that breaks down food in the stomach.

Food is an addiction. We eat all our lives and generally get sick if we stop eating. Thus the Devil represents codependent relations. We depend for our survival on the plants and animals that provide us with food. Sometimes we form codependent relations with other people. Chained to the Devil's pedestal or throne we see two creatures that may be people with horns, people who have descended to their animal natures and simply survive enslaved by their co-dependencies. The lesson of this Trump is to understand the importance of digesting life experiences and incorporating them into our lives without developing codependency. The Devil seems to be our enemy, but actually he is our best friend. He lets us see that our dependencies and the things we reject really are us. By facing this reality and fully digesting the experience we can grow into a new state of love and grace. If God is pure love how could he create an evil Devil? Evil is something that we create for ourselves as an exercise of the freedom that we have. If you want to know why God creates a Devil, then ask yourself why you create a Devil.

The Seven Stages of the Alchemical Process are: Calcination (Burning Off Dross), Dissolution (Letting Go), Separation (Identifying Essences), Conjunction (Creating the Overself), Fermentation (Fire in the Soul), Distillation (Consecration of the Stone), and Coagulation (Appearance of the Soul's Stone Υ JW RP .)]

The Soul's Stone (See Tarot Sky Message) is the famous Philosopher's Stone that grants Wisdom and Immortality. It also transmutes base metals into gold. This is a metaphor for transmuting food into body tissue -- and enlightenment. Food is physical material that comes from that great Stone, the Earth. The Hebrew word for Soul (NPS) may have something to do with alchemy and Anpu, Egyptian God of the Dead. Let us look at the words derived from the root NP in the dictionary. They almost all seem to relate nicely to food, digestion, and alchemy. After each I suggest the stage of alchemy involved. Calcination is heating a substance to a high temperature, but below the melting point. This dries, reduces, and may oxidize the material. Distillation leads to condensation. Coagulation is a more solid form of condensation. The giant hibernating tortoise of meditation supports the physical world.

NP = sprinkle	DISSOLUTION
NPE = sieve, fan, winnow	SEPARATION
NPUE = bloated, swollen, boiling, seething	FERMENTATION
NPUI = sifting, purifying	SEPARATION
NPUL = fallen, degenerate	CALCINATION
NPUTz = diffused, shattered	CALCINATION
NPH = to swell, blow, breathe, become swollen	FERMENTATION
NPH NPS = die	DISSOLUTION
NPHIE = blacksmith	CONJUNCTION
NPT* = naptha, kerosene, oil	CALCINATION
NPT*R = dead	DISSOLUTION (we eat dead flesh)
NPIHE = belch, fart	FERMENTATION
NPIL = giant tortoise	COAGULATION?
NPIL = to be distinct	SEPARATION
NPIL = fallen, defeated	DISTILLATION
NPIS = vacationing	DISSOLUTION?
NPK = precious stone	SOUL'S STONE
NPL = fall, let drop	DISTILLATION
NPL = stillbirth	COAGULATION (failed)
NPLA = wonderful, marvelous	SOUL'S STONE
NPLAUT = miracles	SOUL'S STONE (successful)
NPNP = to swing, flap	?
NP\$R = spoiled, damaged	COAGULATION (failed)
NPO = to revive, blow air into lungs	CONJUNCTION (smith's bellows)
NPOL = reflexive and passive of verb stem	CONJUNCTION (nourish self)
NPTz = burst, shatter, explode, cloudburst	SEPARATION
NPQ = to go out, bring forth	SEPARATION
NPRD = separate	SEPARATION
NPRTz = frequent	(Practice of Alchemy)
NPS = breath, soul, spirit	CONJUNCTION, SOUL'S STONE
NPSO = criminal	DISSOLUTION
NPT = flowing honey, honeycomb	SOUL'S STONE
NPTL = tortuous, perverse	FERMENTATION

Gen. (6:1-5) mentions NPLIM (fallen, stillborn ones), Sons of God that bred with humans. Some believe the Nephilim were degenerate ET's who came to our planet to replenish their DNA diversity.

In the Egyptian Judgment Scene the Devil is Ammit a chimerical pet of Set. Her head is crocodilian, her body is leopard, and her rear is hippo. She waits to eat the heart if it weighs heavier than the feather of Truth. Whenever we eat, we devour parts of ourself. Yet we magically remain a single holistic existence.

22. Lovers (X). The twenty-second Hebrew letter is Tav (numerical value 400, Greek letter Tau T, τ). Of all the organs of the body only one major organ remains to be accounted for. That is the liver. The "Liver" is also the "Lover". This organ is the ally of the Stomach and sits opposite it in the upper abdomen. The two organs work together. The stomach digests food, and the liver breaks down any toxic substances in the food that might harm the body and then stores any extra nutrition as fat. Both Eastern and Western traditions hold beliefs that the liver has something to do with the emotion of love. It has a close connection with the Heart, perhaps because it regulates the levels of toxins and nutrients in the blood. It also has a close connection with the genitals, the seat of sexual love. The Liver Meridian passes down from the liver into the pubic region, where it connects to the Root Chakra located just above the perineum and between the pudendum and sacrum. Then it passes down the middle of the inside of the thigh, on down the leg into the foot.

The pictograph for the letter Tav is an X shape, or a T shape, or a cross shape. TaV is a mark or sign. When illiterate people sign documents they mark with an X. The X can also signal the end, and this is the last letter in the alphabet. TV reversed with the first letter of the alphabet tagged onto it spells the word AVT, a letter of the alphabet, one of the symbols between "A and T". The letter V is the Hebrew symbol for conjunction. We saw in our discussion of the Devil Trump that conjunction is the central step in the alchemical process. One interpretation of the TaV glyph (X) is that it depicts a crossroad. It suggests a choice or selection, the way the liver selects some items for storage and others for detox and others for absorption. Lovers choose each other from among all the available candidates. TAB is desire, and TAWM is a pair of twins. This latter meaning clearly connects the Lovers to the Twins, Gemini. Lovers may not be biological twins, but they share many beliefs and enjoy a lifestyle spent together. Conjunction is definitely an important aspect of this letter.

There is considerable variety in the way that artists render the Lover Trump. Each shows a variation on the theme of how Lovers interact. The Waite and BOTA cards show Adam and Eve, the first couple, receiving the blessing of an angel that looks like Green Man with leaves growing as his hair. Behind him is a huge sun burst, bigger than the Sun on its own Trump card. Again this recalls the Egyptian Aten Flying Solar Disc. Adam and Eve are naked children on the Sun Trump, but are naked adults on the Lovers card. Behind Eve is the Tree of Knowledge of Good and Evil with the Serpent twined about it and whispering in Eve's ear even as she seems to be looking up at the angel. Adam stands on the other side of the card looking at Eve. Behind him is the Tree of Life. It is important to study the body language of the Lovers. It varies in different decks. In the Waite-Smith version we see the dynamics of the interplay between Adam, Eve, the Serpent, and the Angel of God. There is no romance or physical contact between them. But there is a choice that can be made. What would be your choice?

The Visconti-Sforza Lover Trump shows two well-dressed courtiers being blessed in their relationship by a blindfolded angel, suggesting that Love is blind. Neither one of the two Lovers is particularly attractive from a physical viewpoint, but perhaps they will be happy together.

The Oswald Wirth deck shows a handsome young man standing at a crossroad between two attractive ladies. His hands are crossed over his chest, indicating the sign of Tav. The fair-haired lady wears a coronet, is well dressed, and has her hand on his right shoulder. The dark-haired lady has flowers in her hair, has no shoes, and is dressed like a peasant. Her right hand is behind him and her left hand touches his right hand. The man's left foot is close to her right foot. Therefore, although Cupid aims his arrow straight down at the young man without any bias toward either woman, we sense that he will prefer to choose the dark-haired woman, and she definitely wants him. The fair-haired girl with the coronet may also want him, but will tend to control him and may not have pure motivations of love.

In the papyrus of Ani we see the Lovers in the form of Ani and his wife Thuthu dressed in white garments to indicate purification. Ani is a scribe, and Thuthu is a singer and dancer in the Theban temple of Amen. She holds in her hand a sistrum rattle, a musical instrument sacred to Hathor, goddess of Love. If you look closely at the sistrum you can see Hathor's face with its protruding cow ears decorating the top of the handle. Above that on the loop you can see three serpent wires with the rattles strung on them. These rattles were used like Native American gourd rattles for aura purification ceremonies as well as musical performances. The artist drew the couple in the prime of life as a loving couple. On the papyrus they are slightly stooped as they enter the doorway to the Hall of Justice for the Weighing of the Heart to determine if their love is True. On the Trump card I simply turned Ani around to face Thuthu. Their eyes meet in a penetrating gaze and they reach out as if to hold hands.

The names of these lovers are also interesting. The two most common meanings of An are "to bring" (hence a gift) and the pillar of On (Heliopolis, the holy Temple City of the Sun where the benben stone was mounted atop an obelisk). Ani thus would be a man of On. Nuk or Anuk has the meaning of I, the self. Thuthu is the twittering of a bird, a nice name for a singer. Thu also has the meaning "thou". Perhaps we can imagine the Lovers as representing I and Thou in a perfect communion. Thuthu may also be a pun on the name Thoth, transforming it into a woman's name. Thoth thus transforms himself into the Soul Mate.

Study various decks and decide which deck you prefer to work with. Choose a deck in which the Lovers appeal to you in their choice of Love.

The X-shape of the letter Tav can also represent the whole body with its arms and legs spread open. This suggests that Love is a state of openness. It can also suggest the Lovers joined together in the act of making Love. When the body is spread-eagled in this manner we find the Liver and its partner the Stomach located right at the center of the X. So we can say that "X marks" the location of the organ related to this Trump.



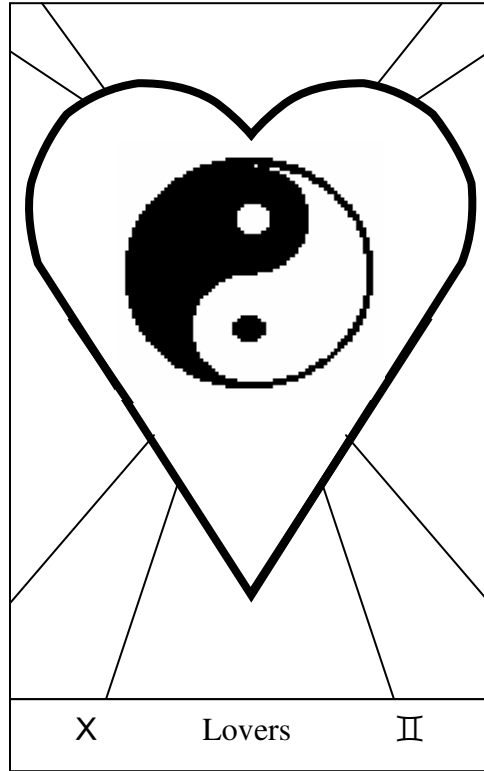
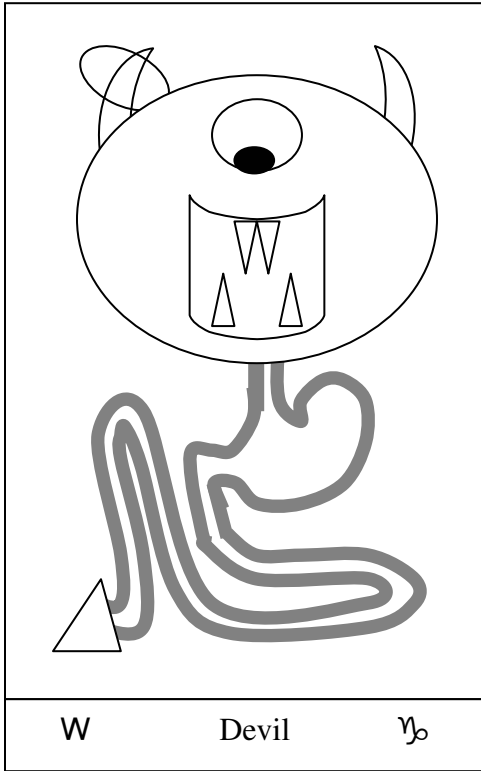

The Book of Thoth: His 22 Triumphs

- ∇ Thoth is the Bull of Maat, archetypal creator, the hidden essence of **Amen-Ra**.
- ◻ TaH*aT means Nether (Egyptian “neter”). Thoth guides Neters in **Seb**’s world.
- ∧ Thoth uses his ankh to protect the future hero **Horus** from the poisons of Set’s scorpion army as Isis suckles him during their sojourn in the papyrus swamp.
- △ Thoth as Hiram, the Master Architect, helps Solomon build the Temple of Jerusalem just as he designed and built the mysterious pyramids and temples of Egypt. The Great Pyramid at Giza is an embodiment of the sacred doorway of **Isis** (Ast).
- ≡ Thoth uses his ankh to restore **Shu**’s Breath of Life to Osiris and resurrect him from the dead to become the archetypal immortal pharaoh.
- Υ The Pope’s staff is another version of the staff of Hermes or **Thoth**’s ankh. Through this he communes with the gods.
- Z Thoth, Master of Immortality, is good friends with **Anpu**, Master of Death.
- ≡ HRM is Hermes Trismegistus who volunteers to hang out below (TH*T), bestowing his compassion in all the three realms with a ladder of evolution. He is Avalokitesvara (**Heru-Khenti-Khaat**), the Bodhisattva about to be born as Buddha.
- ⊗ T*eIT is another name for Thoth as he goes through many transformations in the Cycles of Nature. Thoth Avatars as the **Shai** clay on Khnemu’s Potter Wheel that is shaped into a karmic Fortune..
- ⚡ In his baboon transformation Thoth tames the wild lioness Sekhmet form of **Tefnut**.
- Υ The Hermit wields the staff of Hermes. As Moses he magically liberates Israel from the rule of Pharaoh Ra-Moses, bringing the Jews to Freedom. As Siva he meditates in his Himalayan cave. As the barefoot Apollonius of Tyana he recovers the lost Emerald Tablet of Hermes-Trismegistus from a cave and transmits it to the world. Hermes alchemically transmutes the Heart, **Ib**, into **Bennu**, the Immortal Phoenix.
- ⊢ Thoth presides as scribe during weighing of the Heart in **Maat**’s Scale of Justice.
- W In Genesis God divides the waters into those above (OL) and those below (TH*T). TaH*aT rules the nether waters as Khonsu, the Moon God, companion of **Serqet**.
- ∇ Thoth as an Ibis watches over the Tree of Life and the Starry sky of **Nut**.
- ≡ Horus-Ra’s consort Hathor wields Thoth’s love ankh to bestow life on all creatures.
- Thoth gives **Osiris** the All-Seeing Magic Eye of Horus for enlightened immortality.
- 7 Hermes magically transforms Mercury into Gold in **NebtHet**’s Temple of All.
- ⚡ **Tem** is Shu’s phallus that he masturbates to create the universe. Shu is Maat’s male counterpart, and a hidden transformation of Thoth.
- ♀ Qoph means monkey. Thoth’s foolish **Qeftenu** baboon transformation plays with himself and fiddles with the Scales of Justice.
- P Thoth records the Judgment in the Hall of Justice and presides over resurrection of the dead to be reborn as creations. **Meskenet** assists in their birth as midwife.
- W Thoth-Hermes as the master alchemist, is master of the art of shape shifting and disguise. Even the chimera **Ammit** is in awe of his transformations.
- X Thoth is Science. His consort Maat (Truth) is his One True Love. Thoth gives us the Science of Love and the Love of Science. **Thuthu** embodies Thoth as a beautiful, intelligent, capable, and loving spouse. Her sistrum is a magic Love Ankh.

The Secret Message in the Traditional Hebrew Alphabet Sequence

The Hermetic sequence of the Trumps that I reconstructed is still a hypothesis. There may be refinements to that reconstruction and interpretation that I have not grasped. On the other hand, the traditional Hebrew Alphabet Sequence is something that everybody agrees on. Nevertheless, I have never seen any explanation of why the letters follow that sequence. We know that the Greeks based their alphabet on the same sequence, and the Romans also followed suit. The alphabet we use today is still essentially in the same order with just a few duplications and modifications that have occurred over time. Here is my tentative reading of the alphabet text. We need only a few rules to read the text.

- * The text is reversible.
- * We read in letter pairs (as the Tarot Trump sequence suggests.)
- * We can drop silent finals such as ׀ and ׆.
- * We can insert the semivowels ך or ם.
- * ׀ and ׆ make a secret switch as they do in the other deciphering.
- * ׆׀ and ׀׆ fuse into ׆׀׆. We can add a ך in front to get ׆׆׀׆, Jehovah.
- * ׀ך and ך׀ fuse into ׀ך׀, the clay on the Potter's Wheel of Fortune.
- * We use those two fused forms when reading in either direction.
- * ׀ becomes ׀.

׀׆	Father is
׆[׆]׀, ׆׀[׆]	Penis, Good Fortune, a Kid.
[׆]׆׀׆	IeHoUaH (Being)
׀׆	Moves.
׀ך׀	Clay is
׀׆	All.
׆׀[׆]	Min is; From; Destiny is
׆׀[׆]	Time
׆׆	Scatters
׆׆	Springing Forth; Shouting
׆׆	The Rebel, Set
׀׆	Flies
׆׆	Spit
׆׆	Flood.
׀׆	The Great Bear
׆׆	Sleeps.
׆׆	For You,
׀ך׀	Clay,
׆׆[׆]	The Prophet-Pact
[׆]׆׀׆	Exists; IeHoUaH (Being),
׆׆	The Fish
׆׆	Comes

The above information seems to tell us a mixture of Hebrew and Egyptian ideas that relate to cosmic evolution. We find Khnem the Potter shaping the world. We find the Biblical Jehovah playing the role of Dynamic Existence that generates (Min) Time (Tem) and from that springs forth Set, the Rebel -- conscious thinking man. The flood of spit that flies forth is a creation act by Tem masturbating to spew forth Shu and Tefnut, the gases and stars that form the universe. It could also refer to the Biblical flood. The word TzP (scatter) also recalls Typhon -- Set as Lord of the Pole Star. The Great Bear hibernates in the North at the Pole Star. For the Egyptians this was Set's giant Hippo pet and the Meskhetiu, a prying tool used in the Mouth Opening Ceremony. The prophetic pact may be the covenant with Abraham. Jehovah coming as a Fish could mean populating the earth with creatures or the coming of Christ, or the Phoenician Fish God, Dag. The Kid can be a play on SH, Lamb. This might refer to the Sacrificial Lamb given to Abraham or to Christ as a sacrificial victim. Our next reading adds support to that idea. But recall that Khnum is a Sheep or Goat-like creature. This could be telling us that the Father is Khnemu, the Sheep-Goat Potter who fashions the universe.

We can also combine the forward and reversed readings of each word into a text.

The Father comes. The Penis (Good Fortune, or the Goat Kid) is a Fish. Jehovah exists, or is existence. He moves the prophet. Clay is all for you. Min sleeps. Time is the Great Bear. Scatter the flood. Shout and spit (or spring forth spit.) Set, the Rebel, flies.

If we read 𐌹⊗ as WX, then the Rebel becomes the Basis or the Buttocks, your Seat or Bottom.

We find a few of the same words showing up in the Alphabet Sequence Message that we saw in the Sky Message -- Father, Penis, and Set. So this message must be related.

HU is a secret name for Thoth in ancient Egypt. It relates to the breath and to the Hebrew root HUH, which means "to be" and is the essence of God's name: IHUH. In Hebrew HU becomes He, The Man (3rd person pronoun). Thoth (TeHUTI) and IHUH may be the same name. The Hebrews simply exercised taboo and removed the two T's adding the H in their usual fashion on the end.

There may be other ways to parse the sequence that bring up interesting ideas. For example, toward the end of the Alphabet Sequence we have the curious sequence: 𐌹⊗ 𐌹⊗ 𐌹⊗. The word \$OP can mean a branch or division. But the word TzQR does not occur in Hebrew. Something is going on here. As we saw in the Sky Message, the letters TzR spell the hard flint stone, the philosopher's stone or Soul Stone that keeps coming up. Right in the middle of that letter pair is Q, the letter of the Fool, and the notariqon for the mischievous Monkey form of Thoth. This has to be a hidden reference to Sun Wu-Kung, the foolish magic monkey of the mind in **Journey to the West**. The monkey is born from a stone, gets imprisoned by Buddha in a stone, and then finally becomes a Buddha himself. It can not be an accident that this same foolish monkey figure shows up as Thoth the baboon, as Hanuman, and Vrisha-kapi in India, and then as

Wu-kung in China.

Going back to our word \$OP, we find something else interesting. \$P is a goblet, and O is the Eye of the Magician. Perhaps this is a glyph of the Holy Grail, the Cup of the Magician. The O is the cup within the cup (\$P). \$P H-HKRH is the conscience, or threshold of perception, the intuition. The Eye within the Holy Grail of Conscience is the Eye of Intuition that the Magician opens up. This is the Eye of the Higher Self, the Eye that can see to the End (\$UP), the Limits, and beyond into the AIN \$UP, the Wisdom (Sophia) of infinite unbounded Awareness. Isn't it odd that the word for none in Hebrew (AIN) is almost a perfect homophone with the word for Eye in Hebrew (OaIN). It also means Source, as in a Spring of Living Waters. See Canticles 1:14 OIN GDI: "My beloved is unto me as a cluster of henna in the vineyards of En Gedi." (Spring of My Good Fortune/Goat.) Henna is an herb used for a bright reddish-brown blood-colored dye. In Canticles 7: 5 we find eyes and springs combined in a pun: "Thy neck is as a tower of ivory; thine eyes (OIN) as the pools of Heshbon, by the gate of Bath-rabbim. (BRKUT means pools, but B-RKUT means "in tenderness." Heshbon means Restitution or Revival. Bath-rabbim can mean Big Houses or Big Girls.) Putting it all together we have the Fool-o-Sopher's Stone. \$P-R is the Book, the Story, and the Number to calculate it with.

Putting the Magician and the Fool together again, we have the first two cards of the Tarot Trumps and our old friend OQ -- Jacob the Awkward Heel -- Upside Down Man. We also have subtle hints of Jacob's blind father, Isaac -- [I]Tz[O]Q (note the eye removed) and Jacob's Wisest son, the Diviner of Dreams, Joseph -- [IU]\$[O]P (note the extra eye added). For good measure we even have an echo of Joseph's eldest son and chief heir -- Manasseh (MNSH). That name means "from the Lamb" (M-N S-H), or Min's Kid. Min was the first pharaoh of Egypt and also the God of Fertility, the Source of Life Energy in the Body. He is where we come from and has already shown up in the Message. MN is "from" in Hebrew. For thousands of years in ancient Egypt Min was the totem for the Secret Technology of the transmutation of sexual life force energy into higher states of consciousness. There is also perfect parallelism in that GaD and MiN both mean fortune, and MIN is the archetypal ithyphallic deity, while G[I]D is the penis. GD[I] is a kid, and SH is a lamb. If that is not weird enough for you, then notice that the first phrase neatly says: "The Father is G-D." Contemplate that one. Our English words God and Good almost certainly come from this letter combination that tells us of Good Fortune.

In Gen. 41: 50-52 describes the birth and naming of Joseph's sons. He explains to his Jewish compatriots that the name Manasseh means "From Forgetting" (M-NSH). God has made him forget all his toils and troubles in his father's house. I think this was a true enough gloss, but a cover for the real meaning. There is definitely a pun on MN-OSH, from work. But this could also refer to Min-Isis, or to "From the Great Bear" or "From the Lamb." Joseph was a very high psychic and spiritual person, unlike the rest of his family. He was basically the Pharaoh of Egypt in all but name. He effectively was running the country and was an initiate into the highest secret orders of the Egyptian priesthood. He had to be, because the priesthood would demand close access to the man who held the ear of Pharaoh. Joseph married A\$-NT (Isis-Nut), the daughter of PUT*I-PRO, the High Priest (KHN) of AUN (AN). AN or ON is the

goddess who brings the Eye of Horus-Ra. It means to turn or return, to paint pictures, a writing tablet, beautiful (written with the Eye glyph), and a well or fountain. Like OaIN it also can mean a ring, and extends to mean a seal or signet. The body of Ra (with its opened Eye) was kept at ON. This was a place dedicated to the Immortal Light Beings, the Illuminati or AAKHU. Joseph as the Pharaoh's official Dream Diviner was certainly one of the higher members of this Secret Order. It is hard to tell from the Hebrew transliteration, but Poti-phera's real name in Egyptian was probably something like Ptah-Her, Ptah being the "Opener" god, and Her being Horus. Another possible reading is Ptah-Per-Aa, Opener or Adviser to the Great House -- i.e. to Pharaoh. (Gradually many priests came to use the title Per-Aa, so it was not just reserved for The Emperor Pharaoh.) Joseph called his second son Ephraim (APRIM), supposedly because God had made him fruitful in the land of his affliction. There does seem to be some play in the name on the word "ashes" (APRIM) and "fruitful" (PRH). But we should note that PR means Bull, the symbol of the Creative Life Energy from the Sun, and PRA is the wild ass, such as Hagar's son, Ishmael (Joseph's half grand uncle) who was disowned due to jealousy just as he was. OPR was a famous source of gold, but it also means dust. APRIM sounds close to great grandpa ABRAM's old name, the elder patriarch OBR, and Apis (ABIR), the Almighty Bull God, Lord of Heroes and the Winged Angels. Last, but not least, PROH is pharaoh. So Joseph was honest, but diplomatic. He told the truth, but not quite the whole truth. He was clearly very Egyptianized.

Joseph was a reader of dreams. In Hebrew dream is $\aleph + \omega$. This sounds a lot like the name Khnem transliterated into Hebrew letters. Perhaps Khnem fashions the universe as a magnificent dream in the MIND of the sleeping Min. We already discovered that the Dream of Jacob's Ladder is a secret code in the Bible for the Tarot. Joseph was the most brilliant son of Jacob (Israel). He was his father's dream incarnate. He went to Egypt (kidnapped somewhat like Babaji was) and mastered all of its secrets. These he then passed on to the Jews during their sojourn. This wisdom gradually matured when Moses led the Egyptian Jews back to the old lands of Israel.

Time is the Great Bear that sweeps around the Pole Star like a giant clock in the sky. The "Flying Disc" of Set $\aleph \otimes$ is the Potter's Wheel of Khnem, the Giant Wheel of the Zodiac that spins as it flies through the galaxy, the flood of spit ejaculated by Father Tem to moisten the clay. The Power of the Great Bear is its ability to make artistic Judgments in this setting of Time, even as it sleeps. This is Osiris. (OW-P = 10.) The Ten Judgments of Osiris are the Ten Witness Gods in the Judgment Hall. They form the Ten Commandments of Moses. The Ten plus the Twelve Signs make 22 Trumps. (We are not sorting them in order here, just counting noses.)

SeT is the Root Chakra, the basis for the Tree of Life. The Root Chakra is at the base of the spine in the buttocks, the place (ST) where we sit and shit. For millennia people have held Satan responsible when Shit Happens. This shit is good clay for nourishing the Tree of Life.

Let's try another way to read the Alphabet Sequence backwards with some different parsing and see what we get.

XWP QꞚJ OꞚ[Ꞛ]Ꞛ WꞚYꞚ ⊗ ꞚZY[Ꞛ] Ꞛ∇[Ꞛ]∧ 𐤀𐤅.
 Present a Frothy Masseur. My King Thoth's Prophecy: The Fish Comes.

This reading is pretty odd. There is a gift. The gift is a frothy masseur. This sounds like the Egyptian masturbating creator god giving us the universe from the froth of his massage. My King Thoth (⊗Ꞛ⊗ Clay-man, The Wheel of Fortune) foretells the Coming of the Fish or the Fisherman. Again this message seems to refer back to our reverse reading of the Sky Message. There seems to be a reference to the coming of Jesus in the Piscean Age. This looks like a prophecy about the Fisher King.

Play around with this material and see what you come up with. The alphabet sequence is there for all to see and read. The zodiac is also there for all to see and read. The above exploration is a glimpse into one aspect of the strange and vast world of Qabbalistic Tarot. It is filled with the symbols of the ancient Egyptians and the Old Testament. I have barely cracked this code open, and I am sure there is a lot more to discover. Study of the texts can also reveal to us something about when the sequence of the Hebrew alphabet was fixed, and possibly even a determination of what people did it. There are definite cultural ideas expressed and they represent the confluence of Egyptian, Phoenician, and Hebrew cultures.

The historicity of biblical stories is another matter for the archaeologists and philologists to tussle with. The text as Qabbalistic messages and stories exists quite independent of any historical basis, and much of it may be ethnic allegories. The Egyptians were famous for mythologizing history to the point where it is hard to tell much about the actual events supposedly described. I suspect there is quite a bit of this in the Bible as well. The ancient texts often were intended as cultural indoctrination more than as objective recording of facts. But I believe they contain in their symbols and stories the visions of the wisdom of life as experienced by these ancient cultures.